

C156-E228-02EN

**MCM3064SS, MCM3130SS  
MCP3064SS, MCP3130SS  
OPTICAL DISK DRIVES  
PRODUCT MANUAL**

# FOR SAFE OPERATION

## Handling of This Manual

This manual contains important information for using this product. Read thoroughly before using the product. Use this product only after thoroughly reading and understanding especially the section "Important Alert Items" in this manual. Keep this manual handy, and keep it carefully.

FUJITSU makes every effort to prevent users and bystanders from being injured or from suffering damage to their property. Use the product according to this manual.

This product is designed and manufactured for use in standard applications such as office work, personal devices and household appliances. This product is not intended for special uses (atomic controls, aeronautic or space systems, mass transport vehicle operating controls, medical devices for life support, or weapons firing controls) where particularly high reliability requirements exist, where the pertinent levels of safety are not guaranteed, or where a failure or operational error could threaten a life or cause a physical injury (hereafter referred to as "mission-critical" use). Customers considering the use of these products for mission-critical applications must have safety-assurance measures in place beforehand. Moreover, they are requested to consult our sales representative before embarking on such specialized use.

Fujitsu Limited assumes no liability for data loss or damage that might occur as a result of using this product. To help prevent such loss or damage that might occur in rare cases, back up the data as appropriate.

Second Edition January, 2004

The contents of this manual may be revised without prior notice.

The contents of this manual shall not be disclosed in any way or reproduced in any media without the express written permission of Fujitsu Limited.

All Rights Reserved, Copyright © FUJITSU LIMITED 2002, 2004

# Revision History

(1/1)

Edition	Date	Revised section (*1) (Added/Deleted/Altered)	Details
01	March, 2002	—	—
02	January, 2004	—	—

\*1 Section(s) with asterisk (\*) refer to the previous edition when those were deleted.

This page is intentionally left blank.

# Preface

This manual describes the MCM3064SS, MCM3130SS, MCP3064SS and MCP3130SS 3.5-inch optical disk drives.

This manual provides an overview of the above optical disk drives, and explains their specifications, the requirements and procedures for installing them in a system, and how to clean them.

The manual is intended for users who have a basic understanding of optical disk drives and their use in computer systems.

See "Manual Organization" for details of the organization of manuals related to optical disk drives and the scope of this manual. Use the other manuals shown in "Manual Organization" together with this manual when necessary.

The organization of this manual, related reference manual and conventions for alert messages follow.

## Overview of Manual

This manual consists of the following six chapters, glossary, and abbreviation:

### Chapter 1 General Description

This chapter introduces the MCM3064SS, MCM3130SS, MCP3064SS and MCP3130SS optical disk drives and describes their features, drive configuration, and system configuration.

### Chapter 2 Specifications

This chapter describes the specifications of the MCM3064SS, MCM3130SS, MCP3064SS and MCP3130SS optical disk drives and the specifications of optical disk cartridges.

### Chapter 3 Installation Requirements

This chapter describes the basic environmental, mounting, power supply, and connection requirements for installing the MCM3064SS, MCM3130SS, MCP3064SS and MCP3130SS optical disk drives in a user system.

### Chapter 4 Installation

This chapter describes installation of the MCM3064SS, MCM3130SS, MCP3064SS and MCP3130SS optical disk drive and includes:

- Notes on handling the drive
- Connection modes
- Settings
- Mounting
- Cable connections
- Operation, confirmation, and preparation for use after installation

- Notes on removing the installed drive

## **Chapter 5 Operation and Cleaning**

This chapter describes how to operate and clean MCM3064SS, MCM3130SS, MCP3064SS and MCP3130SS optical disk drives. This chapter also describes how to operate and clean optical disk cartridges.

## **Chapter 6 Diagnostics and Maintenance**

This chapter describes the self-diagnostics functions and maintenance of the MCM3064SS, MCM3130SS, MCP3064SS and MCP3130SS optical disk drives.

## **Chapter 7 SCSI BUS**

This chapter describes in detail the configuration, physical/electrical conditions, interface protocol and operation of the SCSI (Small Computer System Interface), which is an interface for connecting the MCM3064SS, MCM3130SS, MCP3064SS and MCP3130SS optical disk drive and the user system to each other.

## **Glossary**

The glossary describes the technical terms that need to be understood to read this manual.

## **Acronyms and Abbreviations**

This manual contains a list of the abbreviations used in this manual and their meanings.

# **CONVENTIONS USED IN THIS MANUAL**

Throughout this manual, the MCM3064SS, MCM3130SS, MCP3064SS and MCP3130SS optical disk drives are described as an "ODD," "drive," "unit," "target (TARG)," or "device."

Decimal values are indicated without any modifiers added.

Hexadecimal values are indicated as X'17B9', 17B9h, 17B9H, and 17B9H.

Binary values are indicated as "010" and 010b.

If "BUSY LED" is described in this manual, this refers to the LED that is located on the front side (cartridge-loading side) and that indicates the BUSY state of the device. It is described as "LED on the front panel."

## Conventions for Alert Messages

This manual uses the following conventions to show the alert messages. An alert message consists of an alert signal and alert statements. The alert signal consists of an alert symbol and a signal word or just a signal word.

The following are the alert signals and their meanings:



This indicates a hazardous situation *likely* to result in *serious personal injury* if the user does not perform the procedure correctly.



This indicates a hazardous situation *could* result in *serious personal injury* if the user does not perform the procedure correctly.



This indicates a hazardous situation *could* result in *minor or moderate personal injury* if the user does not perform the procedure correctly. This alert signal also indicates that damages to the product or other property, *may* occur if the user does not perform the product correctly.

### IMPORTANT

This indicates information that could help the user use the product more efficiently.

In the text, the alert signal is centered, followed below by the indented message. A wider line space precedes and follows the alert message to show where the alert message begins and ends. The following is an example:

(Example)

### IMPORTANT

While the write cache feature is enabled, a write error is reported in the completion status of another command that is subsequent to the concerned write command. Note that, if the host performs only retry of an error-reporting command, data in the block in which the error has occurred is not correctly written.

The main alert messages in the text are also listed in the “Important Alert Items.”

## Attention

Please forward any comments you may have regarding this manual.

To make this manual easier for users to understand, opinions from readers are needed. Please write your opinions or requests on the Comment at the back of this manual and forward it to the address described in the sheet.

This page is intentionally left blank



# Important Alert Items

## Important Alert Messages

The important alert messages in this manual are as follows:



A hazardous situation *could* result in *minor* or *moderate personal injury* if the user does not perform the procedure correctly. Also, damage to the product or other property, *may* occur if the user does not perform the procedure correctly.

Task	Alert message	Page
Installation	<p><b>Data loss:</b> Data is not guaranteed if a power failure occurs or the I/F cable is pulled out while:</p> <ul style="list-style-type: none"> <li>• Data is being written to a data block</li> <li>• A disk is being initialized (formatted)</li> <li>• Defect processing is in progress</li> </ul> <p>Data is not guaranteed either if the drive is moved with the optical disk cartridge inserted or the drive is exposed to excessive shock or vibration.</p>	2-6
	<p><b>Data loss:</b> When the verify function is invalid, the write data quality is not guaranteed. This mode should not be used for storing important data. When using the mode for storing important data, a preventive system measure such as file duplication is required.</p>	3-23
	<ol style="list-style-type: none"> <li>1) Shock or vibration applied to the drive that exceeds the values defined in the standard damage the drive. Use care when unpacking.</li> <li>2) Do not leave the drive in dirty or contaminated environments.</li> <li>3) Since static discharge may destroy the CMOS devices in the drive, pay attention to the following points after unpacking: <ul style="list-style-type: none"> <li>• Use an antistatic mat and wrist strap when handling the drive.</li> <li>• Hold the mounting frame when handling the drive. Do not touch the PCA except when setting the switches.</li> </ul> </li> <li>4) When handling the drive, hold both sides of the mounting frame. When touching other than both sides of the mounting frame, avoid putting force.</li> <li>5) Do not forcibly push up the end of the header pin of the printed circuit board unit when handling or setting the drive.</li> </ol>	4-1

*Important Alert Items*

Task	Alert message	Page
Installation	Before moving the drive, remove the optical disk cartridge. If the drive is moved with the optical disk cartridge loaded in it, the head may move back and forth in the drive to damage the head or disk and reading the data may fail	4-2
	<ol style="list-style-type: none"> <li>1) The user must not change the settings of terminals not described in this section. The terminals must remain as set when shipped.</li> <li>2) Do not change terminal settings when the power is on.</li> <li>3) To strap setting terminals, use the jumper shipped with the drive.</li> </ol>	4-5
	<ol style="list-style-type: none"> <li>1) Make sure that the system power is off.</li> <li>2) Do not connect or disconnect any cable when the power is on.</li> </ol>	4-13
	<ol style="list-style-type: none"> <li>1) Be careful of the insertion directions of SCSI connectors. For a system in which the terminating resistor power is supplied via the SCSI cable, connecting connectors in the wrong direction may cause the following: The overcurrent protection fuse of the terminating resistor power supply (SCSI device) may blow when power is turned on. The cable may burn if overcurrent protection is not provided.</li> <li>2) Be careful of cable connector positions when connecting more than one SCSI device. The SCSI device having the terminating resistor must be connected to the end of the cable.</li> <li>3) The cables must be kept away from the rotating part of the spindle motor.</li> </ol>	4-14
	Before demounting the optical disk drive, turn off the system power. Do not remove screws securing the cables and drive when the power is on.	4-17
	Cleaning cartridge	<b>Device Damage:</b> Be sure to use the dedicated head cleaner shown above.
<b>Disk damage:</b> To clean a disk, use the cleaning solution and cleaning cloth specified in Table 5.2.		5-10
<b>Disk damage:</b> Do not use this cleaning kit on a floppy disk or an optical disk cartridge to be used on other optical disk drives.		5-11
<b>Disk damage:</b> Clean a cartridge in a dust-free environment. Fujitsu recommends wearing disposable gloves during cleaning so that no fingerprints are left on a disk.		5-11
<b>Disk damage:</b> Do not press hard or apply excessive shock to an optical disk cartridge case while setting it in the setting case.		5-12
<b>Eye inflammation:</b> If the cleaning solution gets into your eyes, immediately wash the solution away with water.		5-13
Maintenance and Repair	<b>Data loss:</b> For a repair request, you normally do not need to include any optical disk cartridge with an optical disk drive. However, you do need to include a cartridge if errors keep occurring with a specific cartridge. In such a case, be sure to save data stored in the cartridge before sending it in. Fujitsu shall bear no responsibility for any data lost during service or repair.	6-3

MANUAL ORGANIZATION

OPTICAL DISK DRIVES  
PRODUCT MANUAL  
(C156-E228)  
<This manual>

1. GENERAL DESCRIPTION
2. SPECIFICATIONS
3. INSTALLATION REQUIREMENTS
4. HOST INTERFACE
5. OPERATION AND CLEANING
6. DIAGNOSTICS AND MAINTENANCE

OPTICAL DISK DRIVES  
SCSI Logical Specifications  
(C156-E092)

1. COMMAND PROCESSING
2. DATA BUFFER MANAGEMENT
3. COMMAND SPECIFICATIONS
4. SENSE DATA AND ERROR RECOVERY
5. SCSI MESSAGES
6. ERROR RECOVERY

## REFERENCED STANDARDS

The product specifications and functions described in this manual conform to the following standards:

Specification (document) number	Name	Concerned organization
ANSI X3.131-1986	American National Standard for Information System - small ComputerSystem Interface (SCSI)	American National Standards Institute (ANSI)
ANSI X3.131-1994	American National Standard for Information System - small ComputerSystem Interface-2 (SCSI-2)	American National Standards Institute (ANSI)
ISO/IEC 10090	90mm Optical Disk Cartridges, rewritable and read only, for data interchange.	ISO/IEC (*1)
ISO/IEC 13963	Data Interchange on 90mm Optical Disk cartridges Capacity: 230 megabytes per cartridges.	ISO/IEC (*1)
ISO/IEC 15041	Data Interchange on 90mm Optical Disk Cartridges Capacity: 640 megabytes per cartridges.	ISO/IEC JTC1 (*1)
Cherry Book Version 1.0	GIGAMO 1.3GB 90mm Magneto-Optical Disk System.	FUJITSU LIMITED SONY CORPORATION

\*1 ISO= International Organization for Standardization

IEC= International Electrical for Commission

JTC1= Joint Technical Committee 1

# Contents

<b>CHAPTER 1</b>	<b>General Description.....</b>	<b>1-1</b>
1.1	Features.....	1-1
1.1.1	Performance and Functions.....	1-1
1.1.2	Reliability.....	1-3
1.1.3	Maintainability/operability.....	1-3
1.1.4	Adaptability.....	1-3
1.1.5	Interface.....	1-4
1.2	Configuration of Optical Disk Drive.....	1-6
1.2.1	Appearance.....	1-6
1.2.2	Configuration.....	1-7
1.2.3	Mechanical section.....	1-7
1.2.4	Control circuit section.....	1-8
<b>CHAPTER 2</b>	<b>Specifications .....</b>	<b>2-1</b>
2.1	Specifications of Optical Disk Drives.....	2-1
2.1.1	Catalog and order numbers.....	2-1
2.1.2	Specifications of drives.....	2-2
2.1.3	Environmental and power requirements.....	2-4
2.1.4	Error rate.....	2-5
2.1.5	Reliability.....	2-6
2.2	Specifications of Optical Disk Cartridges.....	2-7
2.2.1	Recommended optical disk cartridges.....	2-7
2.2.2	Appearance.....	2-8
2.2.3	Specifications of disk.....	2-10
2.3	Defect Management.....	2-11
2.3.1	Defect management schematic diagram.....	2-11
<b>CHAPTER 3</b>	<b>Installation Requirements .....</b>	<b>3-1</b>
3.1	Environmental Requirements.....	3-1

3.1.1	Temperature measurement points.....	3-1
3.1.2	Temperature requirements.....	3-2
3.1.3	Temperature rise.....	3-3
3.1.4	Air flow .....	3-4
3.1.5	Air cleanliness .....	3-4
3.2	Mounting Requirements .....	3-4
3.2.1	Outer dimensions.....	3-4
3.2.2	Installation direction.....	3-10
3.2.3	Center of gravity.....	3-11
3.2.4	Precautions on mounting .....	3-12
3.3	Power Supply Requirements.....	3-14
3.4	Connection Requirement .....	3-17
3.4.1	Connectors and terminals .....	3-17
3.4.2	Cable connection requirements .....	3-19
3.4.3	External operator panel .....	3-20
3.4.4	External operator panel settings (CNH2) .....	3-23

**CHAPTER 4 Installation ..... 4-1**

4.1	Notes on Drive Handling .....	4-1
4.2	Connection Modes .....	4-4
4.3	Settings.....	4-5
4.3.1	Setting switches (SW1) .....	4-7
4.3.2	Setting of supplying power to SCSI terminating resistor .....	4-10
4.3.3	SCSI terminating resistor mode.....	4-11
4.4	Mounting.....	4-12
4.4.1	Checks before mounting the drive.....	4-12
4.4.2	Mounting procedure .....	4-13
4.5	Cable Connections .....	4-13
4.6	Operation Confirmation and Preparation for Use after Installation .....	4-14
4.6.1	Confirming initial operations .....	4-14
4.6.2	SCSI connection check.....	4-15
4.7	Dismounting Drive.....	4-17

---

<b>CHAPTER 5</b>	<b>Operation and Cleaning .....</b>	<b>5-1</b>
5.1	Operation of Optical Disk Drive .....	5-1
5.1.1	Appearance of optical disk drive .....	5-1
5.1.2	Precautions .....	5-2
5.1.3	Inserting an optical disk cartridge.....	5-2
5.1.4	Removing an optical disk cartridge .....	5-4
5.2	Cleaning of Optical Disk Drive.....	5-5
5.3	Operation of Optical Disk Cartridge .....	5-6
5.3.1	Appearance.....	5-6
5.3.2	Write protect tab.....	5-8
5.3.3	Precautions .....	5-9
5.4	Cleaning the Optical Disk Cartridge .....	5-10
5.4.1	Cleaning tool for optical disk cartridge .....	5-10
5.4.2	Cleaning of optical disk cartridge .....	5-11
<b>CHAPTER 6</b>	<b>Diagnostics and Maintenance .....</b>	<b>6-1</b>
6.1	Diagnostics .....	6-1
6.1.1	Initial self-diagnostics .....	6-1
6.1.2	Diagnostic command.....	6-2
6.1.3	Test program .....	6-2
6.2	Maintenance Information .....	6-2
6.2.1	Maintenance requirements .....	6-2
6.2.2	Revision number .....	6-3
<b>CHAPTER 7</b>	<b>SCSI BUS.....</b>	<b>7-1</b>
7.1	System Configuration.....	7-1
7.2	Interface Signal Definition .....	7-3
7.3	Physical Requirements .....	7-6
7.3.1	Interface connector.....	7-6
7.3.2	Interface cable .....	7-9

7.4 Electrical Requirements.....	7-11
7.4.1 SCSI interface.....	7-11
7.4.2 Power supply for terminating resistor .....	7-12
7.4.3 Signal driving conditions.....	7-13
7.5 Timing Rule .....	7-15
7.6 Bus Phases .....	7-18
7.6.1 BUS FREE phase.....	7-18
7.6.2 ARBITRATION phase .....	7-20
7.6.3 SELECTION phase .....	7-22
7.6.4 RESELECTION phase .....	7-24
7.6.5 INFORMATION TRANSFER phases .....	7-26
7.6.6 COMMAND phase.....	7-33
7.6.7 DATA phase.....	7-33
7.6.8 STATUS phase .....	7-36
7.6.9 MESSAGE phase .....	7-36
7.6.10 Signal requirements concerning transition between bus phases .....	7-37
7.6.11 Time monitoring feature.....	7-38
7.7 Bus Conditions.....	7-40
7.7.1 ATTENTION condition .....	7-40
7.7.2 RESET condition.....	7-42
7.8 Bus Sequence.....	7-45

<b>Glossary .....</b>	<b>GL-1</b>
-----------------------	-------------

<b>Acronyms and Abbreviations .....</b>	<b>AB-1</b>
---	-------------

<b>Index .....</b>	<b>IN-1</b>
--------------------	-------------



# Illustrations

## FIGURES

Figure 1.1	The optical disk drive (with panel).....	1-6
Figure 1.2	The optical disk drive (without panel).....	1-6
Figure 1.3	Configuration of optical disk drive.....	1-7
Figure 1.4	Block diagram of the control circuit section.....	1-9
Figure 2.1	Optical disk cartridge .....	2-8
Figure 2.2	Algorithms for alternate processing.....	2-11
Figure 2.3	Example of alternate processing .....	2-12
Figure 3.1	Surface temperature measurement point .....	3-1
Figure 3.2	Outer dimensions .....	3-5
Figure 3.3	Outer dimensions .....	3-7
Figure 3.4	Installation directions.....	3-10
Figure 3.5	Center of gravity .....	3-11
Figure 3.6	Mounting frame structure .....	3-12
Figure 3.7	Service areas .....	3-13
Figure 3.8	MCM3130SS current waveform (+5 VDC) .....	3-14
Figure 3.9	Power on/off sequence (1) .....	3-15
Figure 3.10	Power on/off sequence (2) .....	3-15
Figure 3.11	Power on/off sequence (3) .....	3-15
Figure 3.12	AC noise filter (recommended) .....	3-16
Figure 3.13	Connector and terminal locations .....	3-17
Figure 3.14	Power supply connector.....	3-18
Figure 3.15	Cable connection mode.....	3-19
Figure 3.16	External operator panel circuit example.....	3-21
Figure 3.17	External operator panel interface connector .....	3-22
Figure 4.1	Individual packaging style .....	4-3
Figure 4.2	Gathered packaging style.....	4-3
Figure 4.3	SCSI bus connection modes .....	4-4
Figure 4.4	Positions of setting terminals and switches .....	4-6
Figure 4.5	Setting switch (SW1) .....	4-7
Figure 4.6	SCSI connection check .....	4-16
Figure 5.1	Optical disk drive front view (with panel).....	5-1

Figure 5.2	Inserting an optical disk cartridge .....	5-3
Figure 5.3	Removing an optical disk cartridge .....	5-5
Figure 5.4	Appearance of optical disk cartridge .....	5-7
Figure 5.5	Write protect tab.....	5-8
Figure 5.6	Opening a shutter .....	5-11
Figure 5.7	Setting an optical disk cartridge into the setting case .....	5-12
Figure 5.8	Placing the setting case cover .....	5-12
Figure 5.9	Cleaning of disk surface.....	5-13
Figure 6.1	Revision label.....	6-3
Figure 6.2	Revision number indication .....	6-4
Figure 7.1	Example of SCSI configuration .....	7-2
Figure 7.2	Interface signals .....	7-3
Figure 7.3	DATA BUS and SCSI ID.....	7-4
Figure 7.4	SCSI interface connector (ODD side).....	7-6
Figure 7.5	SCSI interface connector (cable side).....	7-7
Figure 7.6	SCSI interface connector pin assignments (single-ended type)..	7-8
Figure 7.7	Connection of interface cable.....	7-10
Figure 7.8	SCSI termination circuit.....	7-12
Figure 7.9	BUS FREE phase .....	7-19
Figure 7.10	ARBITRATION phase.....	7-21
Figure 7.11	SELECTION phase .....	7-23
Figure 7.12	RESELECTION phase .....	7-25
Figure 7.13	INFORMATION TRANSFER phase (phase control) .....	7-27
Figure 7.14	Transfer in asynchronous mode .....	7-29
Figure 7.15	Transfer in synchronous mode .....	7-32
Figure 7.16	Data transfer rate in asynchronous mode.....	7-34
Figure 7.17	Data transfer rate in synchronous mode.....	7-35
Figure 7.18	Switching direction of transfer over the data bus .....	7-38
Figure 7.19	ATTENTION condition .....	7-42
Figure 7.20	RESET condition.....	7-44
Figure 7.21	Bus phase sequence.....	7-46
Figure 7.22	Example of bus phase transition on execution of a single command .....	7-48

**TABLES**

Table 2.1	Representative model names and order numbers .....	2-1
Table 2.2	Specifications.....	2-2
Table 2.3	Environmental and power requirements .....	2-4
Table 2.4	Recommended optical disk cartridges .....	2-7
Table 2.5	Disk specifications.....	2-10
Table 3.1	Temperature requirements at measurement points .....	3-2
Table 3.2	Temperatures at measuring points (Reference) .....	3-3
Table 3.3	Recommended components for connection.....	3-20
Table 3.4	External operator panel interface.....	3-22
Table 3.5	Device type mode setting.....	3-23
Table 3.6	Write verify mode setting .....	3-23
Table 3.7	Logical specification type setting .....	3-24
Table 4.1	SCSI ID setting (SW1).....	4-8
Table 4.2	SCSI data bus parity checking (SW1) .....	4-8
Table 4.3	Write cache mode setting.....	4-9
Table 4.4	Device type mode settings .....	4-9
Table 4.5	Spindle automatic stop mode setting .....	4-10
Table 4.6	SCSI terminating resistor power supply (CNH1).....	4-10
Table 4.7	SCSI terminating resistor mode (CNH1).....	4-11
Table 4.8	Setting checklist.....	4-12
Table 5.1	Head cleaner.....	5-5
Table 5.2	Cleaning kit.....	5-10
Table 5.3	Packing list for cleaning kit .....	5-10
Table 6.1	Diagnostics function .....	6-1
Table 7.1	INFORMATION TRANSFER phase identification.....	7-5
Table 7.2	Interface cable requirements.....	7-9
Table 7.3	Requirements for terminating resistor power supply.....	7-12
Table 7.4	Signal status .....	7-13
Table 7.5	Signal driving method.....	7-13
Table 7.6	Bus phases and signal sources .....	7-14
Table 7.7	Timing specifications .....	7-15
Table 7.8	SCSI BUS Timing specifications.....	7-17
Table 7.9	Parameters used for synchronous data transfer .....	7-35
Table 7.10	Setting value of SCSI time monitoring.....	7-39

This page is intentionally left blank.

# CHAPTER 1 General Description

- |   |
|---|
| 1.1 Features                            |
| 1.2 Configuration of Optical Disk Drive |

This chapter describes the features and configuration of the MCM3064SS, MCM3130SS, MCP3064SS and MCP3130SS optical disk drives.

As successors to the MCE3064SS and MCE3130SS optical disk drives, the MCM3064SS, MCM3130SS, MCP3064SS and MCP3130SS optical disk drives (hereafter called the optical disk drives) achieve high-speed operation while maintaining compatibility with the MCE3064SS and MCE3130SS.

The flexibility and expandability realized through SCSI interfaces as well as the high performance and command sets of the optical disk drives allow the user to construct disk subsystems featuring advanced functions, high performance, large-scale storage and high reliability.

## 1.1 Features

This section describes the features of the optical disk drives in terms of performance, reliability, maintainability/operability, adaptability, and interface.

### 1.1.1 Performance and Functions

- (1) Half-height standard 90mm(3.5-inch) size (25.4 mm height)

The optical disk drives can be directly connected to the system SCSI bus. The drive employs the same form factor as that for the 90mm(3.5-inch) 25.4-mm height hard disk drive.

- (2) High-speed data transfer

The MCM3130SS and MCP3130SS rotate disks at 3,637 revolutions per minute when 1.3 GB disks are used. When other media are used, the speed is 5,455 revolutions per minute.

The MCM3064SS and MCP3064SS rotate disks at 5,455 revolutions per minute.

In the disk drive, the MCM3130SS and MCP3130SS realize high-speed data transfers at rates of 3.92 to 6.70 MB/s (1.3 GB) and the MCM3064SS and MCP3064SS realize at rates of 3.52 to 5.87 MB/s (640 MB). The maximum synchronous data transfer speed of the SCSI bus is 20 MB/s.

The data transfer capacity can be used effectively through a large capacity data buffer of the optical disk drive.

(3) High-speed mean seek time

This drive features a linear voice coil motor for high-speed head positioning.

The average seek time per 1,000 random seeks is 23 ms. (However, this does not include command overhead or address check.)

(4) Compatibility with international standards (media interchangeability)

The MCM3130SS and MCP3130SS optical disk drives support the use of 90mm(3.5-inch) optical disks in the 1.3 GB format as well as in the 128-MB, 230-MB, 540-MB and 640-MB formats compatible with ISO standards.

The MCM3064SS and MCP3064SS optical disk drives support the use of optical disks in the 128-MB, 230-MB, 540-MB and 640-MB formats compatible with ISO standards.

(5) Dust resistance

With this optical disk drive, the need for a cooling fan has been eliminated owing to its low power consumption. The optical disk drive also has a simple sealed structure. The device is sealed with a metal plate. The drive conforms to class 5 million or less particle level. (Class 5 million: This means there are 5 million dust particles of 0.5 mm diameter or larger per cubic foot. This is equivalent to 0.15 mg/m<sup>3</sup>.)

(6) Lower power consumption

The power consumption of the MCM3064SS, MCM3130SS, MCP3064SS and MCP3130SS optical disk drive is 6.1 W, eliminating the need for a cooling fan. (These power consumption values are typical values during read and write operation.)

The minimum power consumption in the power save modes are 1.2 W.

(7) Automatic spindle stop function

If the optical disk drive is not accessed for a certain duration, it stops disk rotation to minimize dust accumulation on the disk. This duration can be specified using the MODE SELECT command.

### 1.1.2 Reliability

(1) Mean time between failures (MTBF)

The mean time between failures (MTBF) for this optical disk drive is 120,000 hours or more.

(2) Enhanced error recovery

If an error occurs on the optical disk drive, the system executes appropriate retry processing to recover from it. This drive features enhanced Reed-Solomon error correction code (ECC) to assure error-free operation.

(3) Automatic allocation of alternate data blocks

This drive features a function which automatically allocates alternate data blocks in cases where defective data blocks are detected while data is being written to an optical disk.

### 1.1.3 Maintainability/operability

(1) Diagnostics function

This drive has a diagnostics function for checking optical disk drive operations. The diagnostics function facilitates test and restoration.

(2) Five-year service life (no overhaul)

This drive will not require overhaul within the first five years of installation if appropriately maintained (both disks and optical parts cleaned using cleaning tools) and handled as recommended.

### 1.1.4 Adaptability

(1) Wide-ranging operating environments

This drive, requiring low power consumption because of LSIs adopted, can be used in wide-ranging environments (5 to 45°C for drive's ambient environment and a general office environment). The ambient cleanliness must be class 5 million or less particle level.

(2) Low noise

This drive operates quietly at 30 dB or less (A-character) during seek operations and will not degrade the office environment (except when an optical disk is ejected).

(3) Safety standards

The optical disk drive is certified under the following standards:

- UL1950 (U.S. safety standard)
- CDRH (U.S. laser standard) (Class 1)
- CSA C22.2 No. 950 (Canada safety standard)
- EN60950 (European safety standard)
- EN60825-1 (European laser standard) (Class 1)

(4) Radio wave standards

This optical disk device, while installed, is certified under the following standards:

EN55022 class B, EN55024 (European EMC standard)

AS/NZS3548 class B (Australian EMC standard)

CNS13438 class B (Taiwanese EMC standard)

### **1.1.5 Interface**

(1) Conformation to SCSI-2

The optical disk drives conform to the basic specifications of SCSI-2.

SCSI commands specify data with logical block addresses, thus allowing data to be manipulated independent of the physical characteristics of the optical disk drives. This facilitates easy development of software whose functions can be flexibly expanded in the future.

(2) Continuous block processing

Logical block addresses are used for data block addressing. Irrespective of the physical attributes of track boundaries, you can have the initiator access data by specifying a block number in logically continuous data space.

(3) High-capacity data buffer

This drive has a 2 MB data buffer. This data buffer is used to transfer data between the SCSI bus and a disk. Since data is stored in this buffer, the host can execute input-output processing effectively by using the data transfer capability of the SCSI bus irrespective of the effective data transfer rate of the optical disk drive.



(4) Read-ahead cache feature

The read-ahead cache feature enables high-speed sequential data access as follows:

After executing a command to read data from the disk, the drive automatically reads the next data block and stores it in the data buffer (pre-reading). If the next command requests this data, the drive can transfer data from the buffer without accessing the disk again.

(5) Write cache feature

When the host system issues the write command to the optical disk drive, this drive would report completion of the command after completion of the write and verify operations if the write cache feature were not used. If the write cache feature is used, this drive reports completion of the command when data transfer to buffer is completed, without waiting for completion of the write and verify operations. This drive performs the write and verify operations asynchronously with the interface operation. Therefore, enabling the write cache reduces the apparent write command processing time recognized by the host system and improves the I/O performance of the host system.

Enable or disable the write cache feature using the MODE SELECT command.

**IMPORTANT**

While the write cache feature is enabled, a write error is reported in the completion status of another command that is subsequent to the concerned write command. Note that, if the host performs only retry of an error-reporting command, data in the block in which the error has occurred is not correctly written.

(6) Defective block slipping

While initializing a disk, the optical disk drive slips defective data blocks to reallocate logical data blocks so they are physically continuous. This enables high-speed continuous data block processing without rotational delay due to defective data blocks.

## 1.2 Configuration of Optical Disk Drive

### 1.2.1 Appearance

Figures 1.1 and 1.2 show the optical disk drive.

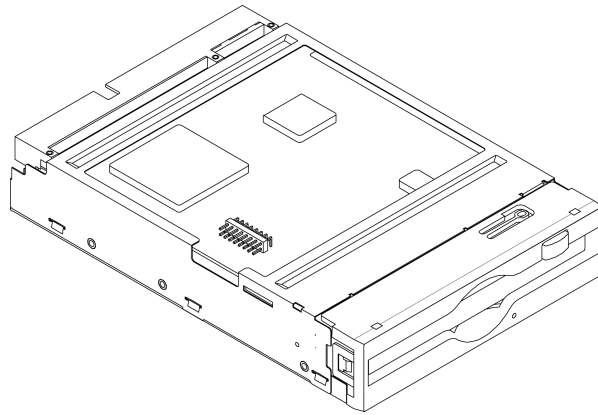

**Figure 1.1 The optical disk drive (with panel)**

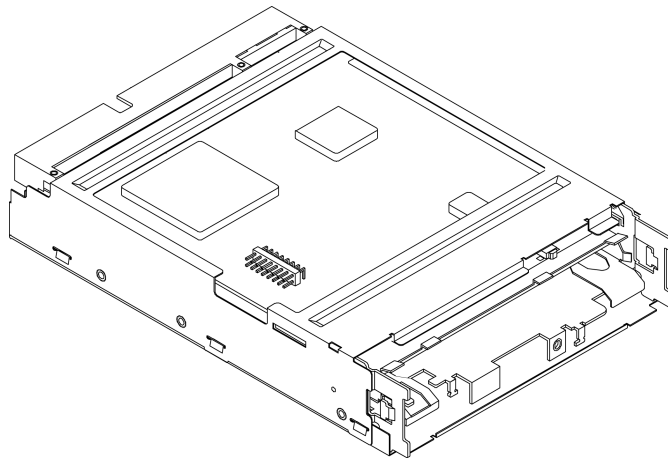

**Figure 1.2 The optical disk drive (without panel)**

## 1.2.2 Configuration

Figure 1.3 shows the configuration of the optical disk drive.

The optical disk drive consists of a mechanical section, a fixed optics section, a control circuit section, and an actuator.

The mechanical section includes the spindle motor, actuator section, bias magnet, and cartridge holder vertical motion mechanism.

The fixed optics section consists of the optical components, position detector, and LD controller.

The control circuit section includes the drive control circuit section and I/F circuit section.

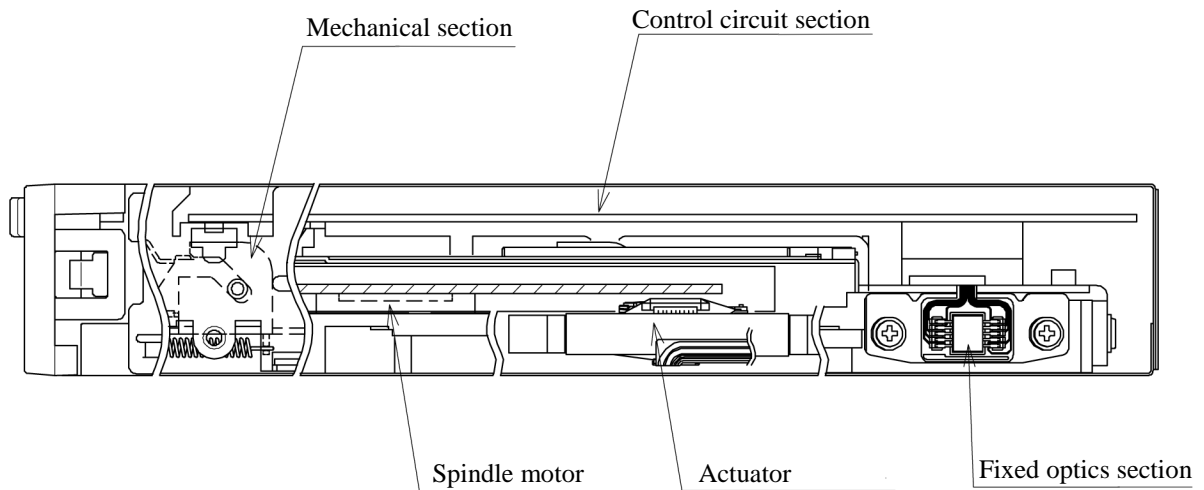

**Figure 1.3 Configuration of optical disk drive**

## 1.2.3 Mechanical section

### (1) Loading and ejecting an optical disk cartridge

The optical disk drive includes a cartridge load mechanism and an auto eject mechanism. If an optical disk cartridge is manually inserted in the drive's slot as far as it will go, the cartridge load mechanism automatically lowers the cartridge and mounts it on the spindle motor. If the Eject button on the front panel is pressed, the auto eject mechanism automatically ejects the cartridge.

### (2) Spindle motor

An optical disk cartridge hub and the spindle motor shaft are magnetically combined. Therefore, a disk rotates as fast as the spindle motor shaft rotates. The spindle motor, a DC brushless motor, provides high-speed rotation at 5,455 rpm and 3,637 rpm and high-accuracy rotation at  $\pm 0.1\%$ .

(3) Actuator section

The actuator section consists of a focus actuator and a tracking actuator. The former focuses a laser beam on the surface of an optical disk while the latter moves the beam spot along the radius, on the surface of an optical disk (seek operation).

The actuator section is directly driven by a linear voice coil motor. The tracking actuator is based on the pulse-width modulation (PWM) system and realizes low power consumption and high-speed access.

(4) Separate optical sections

The optical head section has a split structure in which the fixed optics section is separated from the moving optics section to minimize seek time and positioning error. This reduces the weight of the moving parts.

The fixed optics section consists of the laser diodes, collimator lens, separation prism, condensing lens, and the optical detector.

A laser diode for recording and playback transmits one laser beam to the actuator section.

(5) Panel

The central part of the panel is hollowed out to provide enough space to enable the cartridge to be inserted by pushing it with a finger, thereby facilitating insertion.

The panel is also simply designed using an eject button that also serves as LED light emitting part.

### **1.2.4 Control circuit section**

Figure 1.4 is a block diagram of the control circuit section and the peripheral sections.

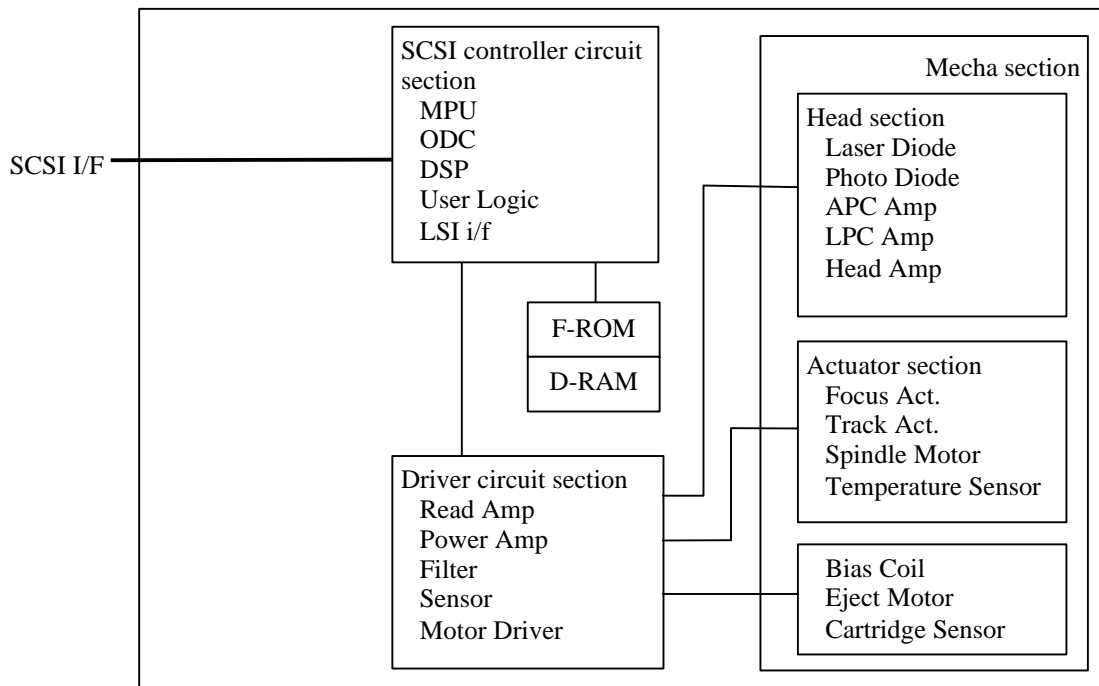

**Figure 1.4 Block diagram of the control circuit section**

The control circuit consists of a SCSI controller, which controls operations between the SCSI interface and the drive interface, and a device circuit section, which controls the drive circuit.

(1) SCSI controller circuit section

The SCSI controller circuit, which uses an LSI for improved reliability, controls the drive through SCSI interface control, read-write control, beam control, etc., by using one high-speed microprocessor (MPU).

(2) Drive circuit section

The drive circuit section consists of the laser diode light emitting control circuit, signal reproduction circuit, servo/seek control circuit, rotation control circuit, and other control circuits. In particular, the servo/seek control circuit consists of a DSP (digital signal processor) for circuit reduction and the realization of a simple configuration.

The drive circuit section performs the seek, erase, record, and playback operations while controlling the focus tracking of the beam.

This page is intentionally left blank.

# CHAPTER 2 Specifications

- 2.1 Specifications of Optical Disk Drives
- 2.2 Specifications of Optical Disk Cartridges
- 2.3 Defect Management

This chapter provides the specifications of the optical disk drives and the optical disk cartridge.

## 2.1 Specifications of Optical Disk Drives

### 2.1.1 Catalog and order numbers

Table 2.1 lists the model names (catalog numbers) and order numbers of optical disk drives.

**Table 2.1 Representative model names and order numbers**

Model name (catalog number)	Order No.	Panel	Panel color	Mounting screws
MCM3064SS	CA06086-B431	With panel	Light gray	Metric screws (M3)
MCM3130SS	CA06123-B431	With panel	Light gray	Metric screws (M3)
MCP3064SS	CA06298-B631	With panel	Light gray	Metric screws (M3)
MCP3130SS	CA06363-B631	With panel	Light gray	Metric screws (M3)

## 2.1.2 Specifications of drives

Table 2.2 lists the specifications of MCM3064SS, MCM3130SS, MCP3064SS and MCP3130SS optical disk drives.

**Table 2.2 Specifications (1 of 2)**

[MCM3064SS, MCM3130SS, MCP3064SS and MCP3130SS]

Item		Specifications				
Optical disk media		128 MB media	230 MB media	540 MB media	640 MB media	1.3 GB media (*7)
Storage capacity (one side)	Unformatted	181 MB	325 MB	819 MB	818 MB	1.688 GB
	Formatted	128 MB	230 MB	538 MB	643 MB	1.283 GB
Capacity per track	Unformatted	18,100 bytes	18,100 bytes (logical track capacity)	19,450 bytes (logical track capacity)	43,928 bytes (logical track capacity)	45,798 bytes (logical track capacity)
	Formatted	12,800 bytes	12,800 bytes (logical track capacity)	12,800 bytes (logical track capacity)	34,816 bytes (logical track capacity)	34,816 bytes (logical track capacity)
Capacity per sector	Unformatted	725 bytes	725 bytes	778 bytes	2,584 bytes	2,631 bytes
	Formatted	512 bytes	512 bytes	512 bytes	2,048 bytes	2,048 bytes
Number of user tracks/side (*1)		10,000	17,940	42,042	18,480	36,855
Number of alternate sectors/side		≤1,024	≤1,025	≤2,250	≤2,244	≤4,437
Number of sectors/track		25	25	25	17	17
Data transfer rate		1.65 MB/s (maximum) 0.39 MB/s continuous writing (execution) 1.16 MB/s continuous reading (execution)	2.00 to 3.16 MB/s (maximum) 0.47 to 0.75 MB/s continuous writing (execution) 1.40 to 2.23 MB/s continuous reading (execution)	3.54 to 5.94 MB/s (maximum) 0.78 to 1.30 MB/s continuous writing (execution) 2.33 to 3.91 MB/s continuous reading (execution)	3.52 to 5.87 MB/s (maximum) 0.93 to 1.55 MB/s continuous writing (execution) 2.79 to 4.66 MB/s continuous reading (execution)	3.92 to 6.70 MB/s (maximum) 0.99 to 1.70 MB/s continuous writing (execution) 2.98 to 5.09 MB/s continuous reading (execution)
Average seek time (*2)		23 ms (typ)				
Average latency		5.5 ms				8.2 ms
Rotational speed		5,455 rpm ±0.1%				3,637 rpm ±0.1%
Heads		Positioner + Separated optical components				
Positioner type		1 (Linear voice coil motor)				
Servo tracking method		ISO continuous servo method				
Recording density		24,424 bpi (1.04µm/bit) 15,875 TPI	29,308 bpi (0.87µm/bit) 18,275 TPI	52,900 bpi (0.48µm/bit) 23,090 TPI	89,100 bpi (0.285µm/bit) 28,200 TPI	
Loading time (*3)		8 sec. (typ)				12 sec. (typ)
Unloading time (*4)		4 sec. (typ)				
Load/unload life		20,000				
Host interface		SCSI-2 (FAST20)				
Data transfer rate (*5)		Synchronous mode: 20 MB/s (max.) Asynchronous mode: 5 MB/s (max.)				



**Table 2.2 Specifications (2 of 2)**

Item	Specifications				
Optical disk media	128 MB media	230 MB media	540 MB media	640 MB media	1.3 GB media (*7)
Data buffer	2 MB				
Error correction (*6)	Correctable up to 8-byte/interleave Bit error rate: $10^{-12}$ or less				

- \*1 The number of user tracks indicates the maximum user zone which includes the spare area and slipping area.
- \*2 Mathematical average of 1,000 times of random seek, which does not include command overhead or track address recognition time. Furthermore, it may depend on the quality of the media and the drive installation environment.
- \*3 Loading time is the time that elapses from the time an optical disk cartridge is inserted, to the time the optical disk drive is ready for processing of an access command.
- \*4 Unloading time is the time that elapses from the time the eject button is pressed or the eject command is issued, to the time an optical disk cartridge is ejected.
- \*5 The maximum SCSI data transfer rate may be limited by the initiator response time, SCSI bus transfer characteristics, or transfer distance.
- \*6 The bit error rate must be  $10^{-12}$  or less using a disk whose raw error rate is  $10^{-4}$  or less.
- \*7 The MCM3064SS and MCP3064SS do not support 1.3-gigabyte MO disks.

#### Power save mode

Power save mode	1	2	3
Time for entering power save mode (continuous time without accessing from SCSI)	2 sec.	5 min	33 min
Power consumption (*8)	3.9 W	2.0 W	1.2 W
Returning time to normal mode (*8)	100 ms	1.0 sec.	5.0 sec.

- Power save mode 1: Read Amp., Bias off
- Power save mode 2: Servo off, Clock frequency down
- Power save mode 3: Spindle off, LD off

- \*8 Average values in case of environment of a temperature of 25-C, voltage of 5 V and without terminating resistor.

### 2.1.3 Environmental and power requirements

Table 2.3 lists the environmental and power requirements.

**Table 2.3 Environmental and power requirements (1 of 2)**

Item		Specification	
Power requirements	Average	+5 VDC±5% (*1), 1.2A (2.7A max) Ripple requirement 100mV pp (DC-1 MHz)	
Power consumption (Average)	Ready	3.9 W (typ) (*2)	
	Random seek, read or write	6.1 W (typ) (*2)	
	Power save mode	Pre-idle mode	3.9 W (typ) (*2)
		Idle mode	2.0 W (typ) (*2)
Standby mode		1.2 W (typ) (*2)	
Sleep mode		1.2 W (typ) (*2)	
Outer dimensions (W × D × H)	With panel	101.6×150.0×25.4 mm	
	Without panel	101.6×148.4×25.4 mm	
Weight		410 g (with panel)	
Environmental requirements	Operating	Temperature: 5 to 45°C (gradient 15°C /h or less) (*3)	
		Relative humidity: 10 to 85% (No condensation) Maximum wet bulb temperature: 29°C or lower	
	Idle	Temperature: 0 to 50°C Relative humidity: 10 to 85% (No condensation) Maximum wet bulb temperature: 36°C or lower	
Transport	Temperature: -40 to 60°C (24 hours or less) Temperature: -20 to 60°C (24 hours or more) Relative humidity: 5 to 90% (No condensation) Maximum wet bulb temperature: 41°C or lower		
Installation	Tilt angle	-5° to +10° (*3)	

**Table 2.3 Environmental and power requirements (2 of 2)**

Item		Specification
Vibration/ shock	Operating	3.92 m/s <sup>2</sup> {0.4 G} (5 to 500 Hz, Sine Sweep) Shock 19.6 m/s <sup>2</sup> {2 G} (10 ms, Half Sine Pulse)
	Idle No cartridge, power ON	9.8 m/s <sup>2</sup> {1.0 G} (5 to 500 Hz, Sine Sweep) Shock 49 m/s <sup>2</sup> {5 G} (10 ms, Half Sine Pulse)
	Transport	Shock 980 m/s <sup>2</sup> {100 G} (10 ms, Half Sine Pulse) Requirement: Packing specifications specified by Fujitsu
Altitude	Operating	3,000 m (10,000 ft) or less
	Idle	12,000 m (40,000 ft) or less
Ambient cleanliness	Air flow	Not required
	Air purity	General office environment or better (dust particle level: Class 5 million or less particle level)

\*1 During random seek or read/write but excluding pulse waveform at 500  $\mu$ s or less

\*2 Average value at an ambient temperature of 25°C and a voltage of 5 V

\*3 The performance is specified at an ambient temperature of 25°C and level placement at 0°.

Note:

1. The current limiter value on the power supply must not exceed 5 A.
2. The specifications for during transport are under the packaging conditions specified by Fujitsu.
3. Note that, concerning the power requirements, a voltage drop may occur depending on the power cable in use.

#### 2.1.4 Error rate

Data blocks to be accessed should be evenly distributed on the disk. Errors due to disk defects are not included.

##### (1) Bit error rate after ECC processing

The error rate after ECC processing must be  $10^{-12}$  or less. An optical disk whose raw error rate is  $10^{-4}$  or less should be used.

##### (2) Positioning error rate

The positioning error rate must be  $10^{-6}$  or less (with retry).

## 2.1.5 Reliability

### (1) Mean time between failures (MTBF)

The MTBF is 120,000 hours or more. Failures due to disk errors are not included.

Conditions

- Power-on time: 200 hours/month or less
- LD-on time: 20% or less of power-on time
- Ambient temperature: 25°C

Note: The MTBF is defined as follows:

$$\text{MTBF} = \frac{\text{Total operating time in all fields (hours)}}{\text{Number of device failure in all fields}}$$

- 1) Operating time is the total time in which power is supplied.
- 2) Device failures include failures requiring repair, readjustment, or replacement. However, they do not include failures that are not due to the optical disk drive itself but to external factors such as careless device handling, nonsupport of environmental requirements, power failures, host system errors, and interface cable errors.

### (2) Service Life

This drive will not require overhaul within the first five years of installation if properly maintained (both disk media and optical parts cleaned) and handled as recommended.



#### **Data loss:**

Data is not guaranteed if a power failure occurs or the I/F cable is pulled out while:

- Data is being written to a data block
- A disk is being initialized (formatted)
- Defect processing is in progress

Data is not guaranteed either if the drive is moved with the optical disk cartridge inserted or the drive is exposed to excessive shock or vibration.

## 2.2 Specifications of Optical Disk Cartridges

### 2.2.1 Recommended optical disk cartridges

Optical disk cartridges basically comply with the ISO/IEC 10090 standard for 128 MB capacity, ISO/IEC 13963 standard for the 230 MB capacity, and ISO/IEC 15041 standard for the 540 and 640 MB capacity.

Table 2.4 shows the specifications of the optical disk cartridges recommended for this optical disk drive. The specified drive performance may not be obtained if other disk cartridges are used.

**Table 2.4 Recommended optical disk cartridges**

Model	Drawing number
Optical disk cartridge (540 MB) with Media ID	CA90002-C037
Optical disk cartridge (640 MB) with Media ID	CA90002-C016
Optical disk cartridge (1.3 GB) with Media ID	CA90002-C017

## 2.2.2 Appearance

Figure 2.1 shows an optical disk cartridge. The names of the components of an optical disk cartridge are also shown.

(a) Shutter closed

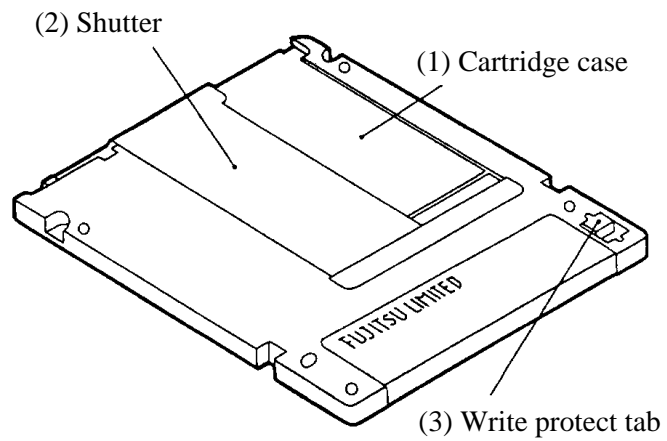

**Figure 2.1 Optical disk cartridge (1 of 2)**

(b) Shutter open

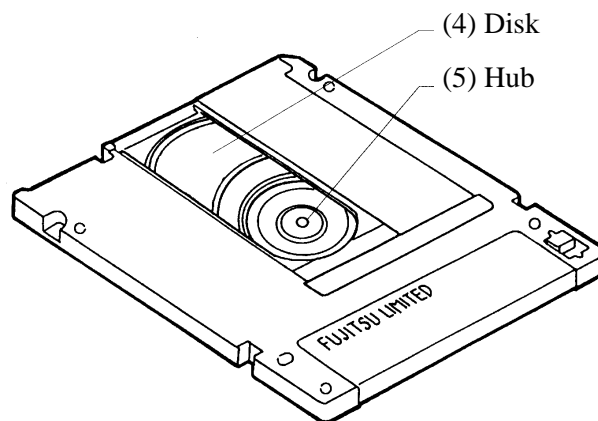

**Figure 2.1 Optical disk cartridge (2 of 2)**

The following explains the components of the optical disk cartridge shown in Figure 2.1.

1) Cartridge case

The disk housing is provided to protect the disk from damage when handling it, and facilitates replacement of the disk.

The cartridge case has a label and a write protect tab on it.

2) Shutter

The shutter protects the disk from contamination. This metallic door opens when the cartridge is inserted into the optical disk drive.

3) Write protect tab

Slide the write protect tab to enable or disable writing to the disk.

4) Disk

Stores data that can be read or written using a laser beam.

5) Hub

The hub is the central disk part to be connected to the spindle of the optical disk drive.

The hub is used for radial centering and axial positioning.

### 2.2.3 Specifications of disk

Table 2.5 lists the disk specifications.

**Table 2.5 Disk specifications**

	Item	Specification
Reliability	Read cycle	$>10^8$
	Erase/write/read cycle	$>10^6$
	Load/unload cycle	25,000
	Archival life (in accordance with acceleration test results)	$>10$ years (*1)
	Shelf life (in accordance with acceleration test results)	$>10$ years (*2)
Environmental requirements	Operating temperature	5 to 55°C
	Operating relative humidity	3 to 85% RH (*3)
	Storage temperature	-20 to 55°C
	Storage humidity	3 to 90% RH (*3)

\*1 Archival life indicates the maximum period during which recorded information can be read from a disk.

\*2 Shelf life indicates the maximum period during which information can be written to an unrecorded disk.

\*3 Maximum wet bulb temperature = 29°C.

Note: Non-recommended disks, if used, must be subject to a compatibility check by the customer.

(1) 128 MB media

The ISO/IEC10090 defines 128-MB media specification.

(2) 230 MB media

The ISO/IEC13963 defines 230-MB media specification.

(3) 540 MB/640 MB media

The ISO/IEC15041 defines 540 MB/640 MB media specification.

(4) 1.3 GB media

The Cherry Book version 1.0 defines 1.3 GB media specification.



## 2.3 Defect Management

### 2.3.1 Defect management schematic diagram

Defective sectors on the disk must be replaced with good sectors in accordance with the defect management scheme as follows: Sectors found defective during surface inspection are handled using a sector slipping algorithm. Sectors found defective after initialization are replaced using a linear replacement algorithm.

Figure 2.2 shows the sector slipping and linear replacement algorithms.

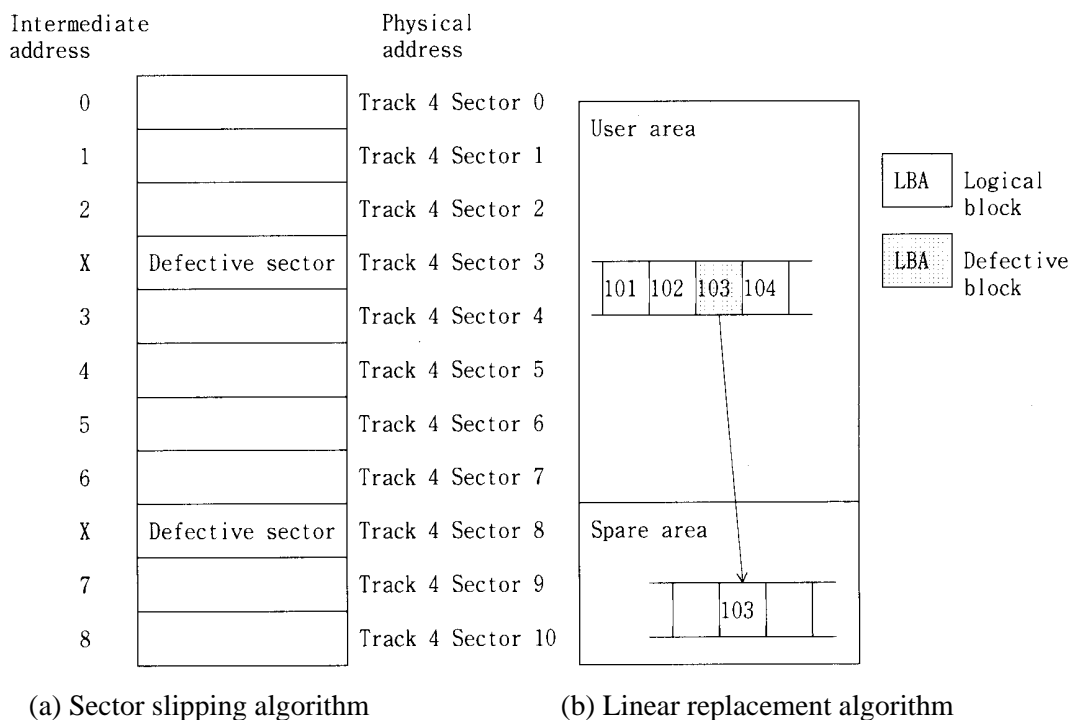

**Figure 2.2 Algorithms for alternate processing**

During initialization, the user area is divided into several groups. Each of the groups contains data sectors and spare sectors. Spare sectors are used as replacements for defective data sectors. During initialization, the surface inspection over the user area can be performed.

Figure 2.3 shows an example of alternate processing.

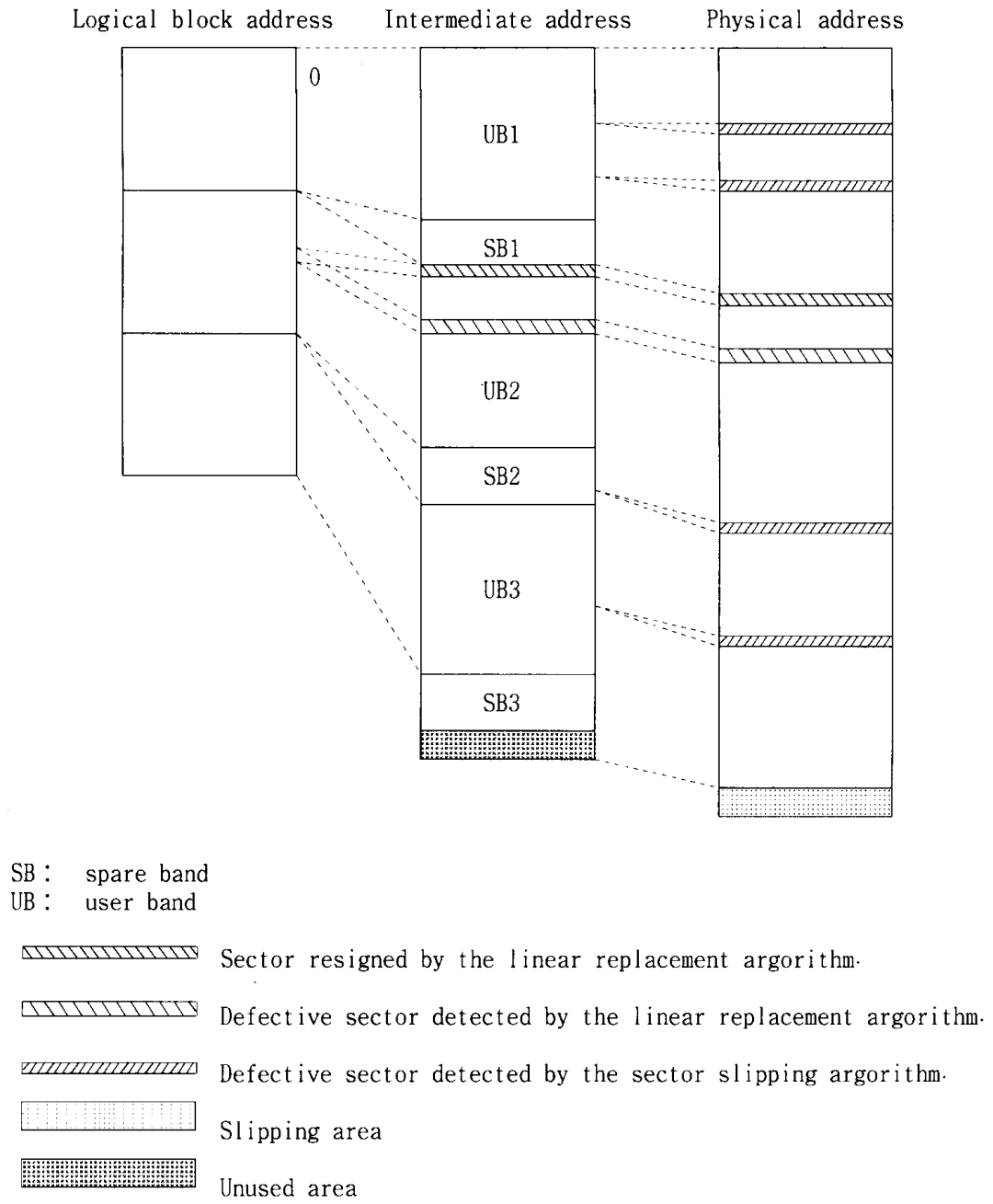

**Figure 2.3 Example of alternate processing**

# CHAPTER 3 Installation Requirements

3.1	Environmental Requirements
3.2	Mounting Requirements
3.3	Power supply Requirements
3.4	Connection Requirement

This chapter describes environmental, mounting, power supply, and connection requirements.

## 3.1 Environmental Requirements

The optical disk drive must be installed in an environment complying with the ambient environmental requirements defined in Section 2.1.3.

### 3.1.1 Temperature measurement points

While the drive is operating, the ambient temperatures measured 3 cm away from the surfaces of the optical disk drive must satisfy the ambient environmental requirements specified in Section 2.1.3. As for the surface temperatures during operation, the contact temperatures measured at the points shown in Figure 3.1 must satisfy the temperature requirements specified in Section 3.1.2.

(a) Inside optical disk cartridge

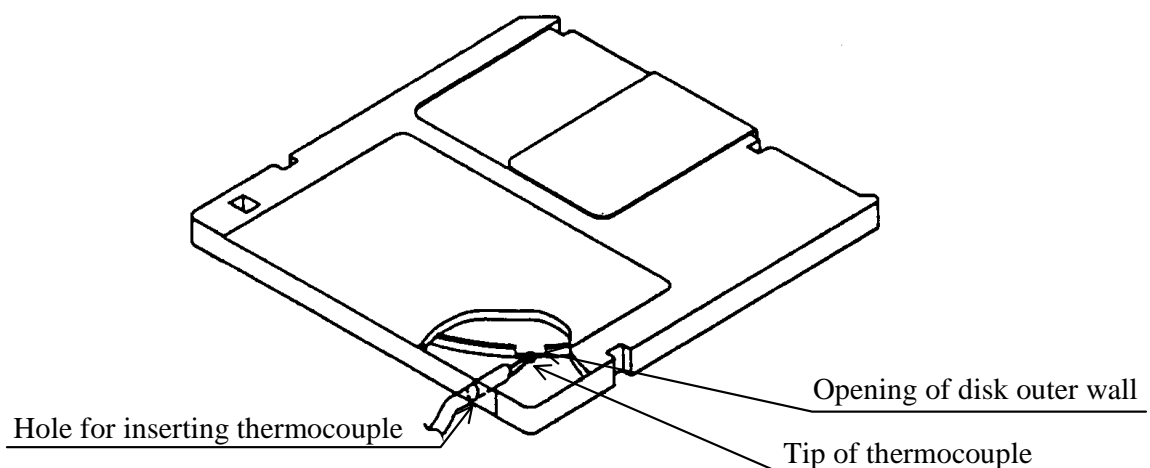

**Figure 3.1 Surface temperature measurement point (1 of 2)**

(b) IC (controller, read Amp)

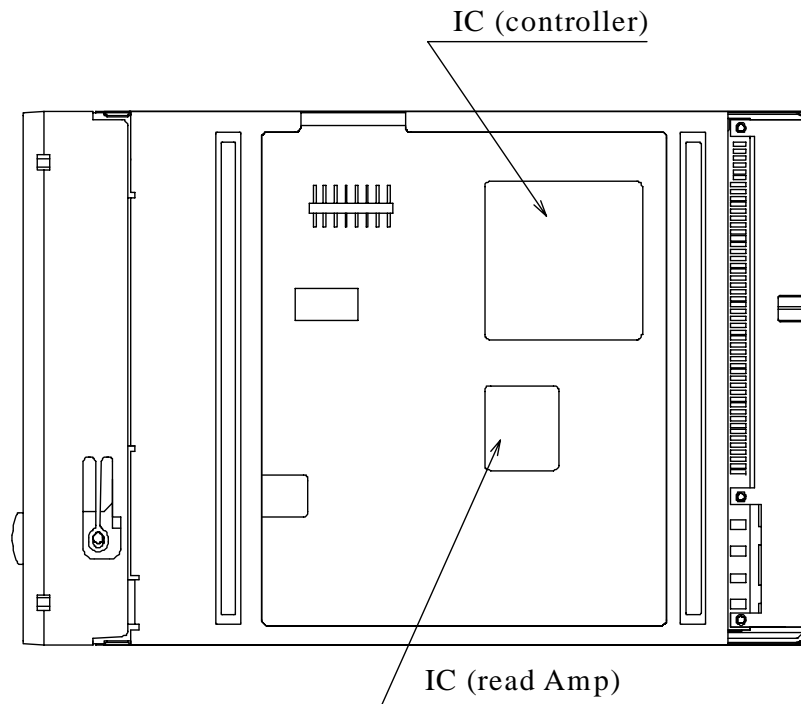

**Figure 3.1 Surface temperature measurement point (2 of 2)**

### 3.1.2 Temperature requirements

Table 3.1 shows the temperature requirement at the measurement point shown in Figure 3.1.

**Table 3.1 Temperature requirements at measurement points**

Measurement point	Maximum allowable surface temperature
Inside the cartridge	55°C (*1)
IC (controller) surface	85°C
IC (read Amp.) surface	85°C

\*1 60°C for the optical disk cartridges recommended by Fujitsu (except 1.3 GB).

The following describes a procedure for measuring the temperature inside a cartridge.

- 1) At the bottom of the cartridge, open a hole large enough for the thermocouple to be inserted as shown in Figure 3.1.
- 2) Disassemble the cartridge.

- 3) Cut off part of the wall surrounding the optical disk (disk outer wall) as shown in Figure 3.1.

At this point, cut off a section 5 to 10 mm in width from the disk outer wall.

- 4) Using an adhesive agent, affix the tip of the thermocouple to the opening of the disk outer wall.
- 5) Pass the thermocouple through the hole in the cartridge and reassemble the cartridge.

Using an adhesive agent, etc., fill any gap between the hole and the thermocouple.

Note: The surface of the cartridge shown in Figure 3.1 has been cut away to illustrate the elements inside the cartridge. Do not actually cut away the surface.

If the external environment temperature rises above the specified value, the drive will take protective action to deal with the temperature increase by automatically placing an interval between commands before responding to a command.

### 3.1.3 Temperature rise

**Table 3.2 Temperatures at measuring points (Reference)**

[Ambient temperature of the optical disk drive: 45°C]

Measurement point	Random seek	Criteria
Inside cartridge	53°C	55°C
IC (controller) surface	73°C	85°C
IC (read Amp.) surface	75°C	85°C
Thermal sensor	51°C	—

Notes:

1. The above data was taken in a constant temperature chamber in which the temperature around the optical disk drive was kept at 45°C. The data was not taken with the drive installed in a box in which the drive is actually used.
2. Note that, when installed in a box, the ambient temperature around the drive will differ depending on the air circulation conditions of the box, and the temperature increase inside the cartridge will differ accordingly.

### **3.1.4 Air flow**

It is recommended that this optical disk drive be installed in a fanless cabinet. However, if the power supply is included in the same cabinet, the “Temperature Conditions” in 3.1.2 must be met. Furthermore, we recommend that the speed of air drawing in by the device from the left side of the cartridge loading slot in the front panel dose not exceed 0.3m/s for MCM3064SS or MCM3130SS, and dose not exceed 0.1m/s for MCP3064SS or MCP3130SS. If this unit is to be used as a built-in drive, the system fan (if one is supplied) must meet the same conditions.

### **3.1.5 Air cleanliness**

The air cleanliness in the device environment is expressed by the number of dust particles per unit area. Fujitsu recommends using the optical disk drive in the environment of class 5 million or less particle level. (Class 5 million: This means there are 5 million dust particles of 0.5  $\mu\text{m}$  diameter or larger per cubic foot. This is equivalent to 0.15  $\text{mg}/\text{m}^3$ .)

## **3.2 Mounting Requirements**

### **3.2.1 Outer dimensions**

Figures 3.2 to 3.3 show the outer dimensions of the optical disk drive and the positions of the mounting holes.

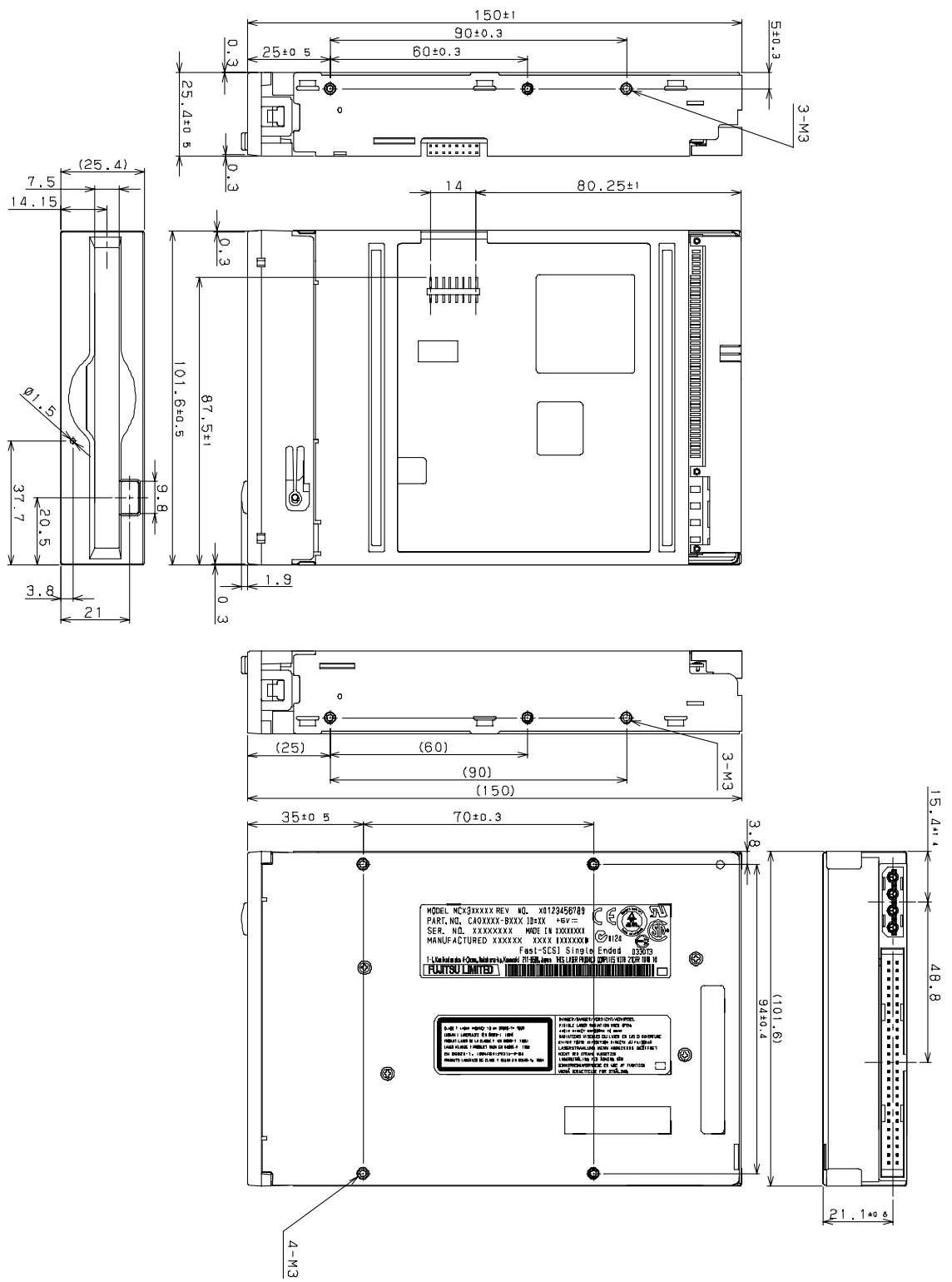
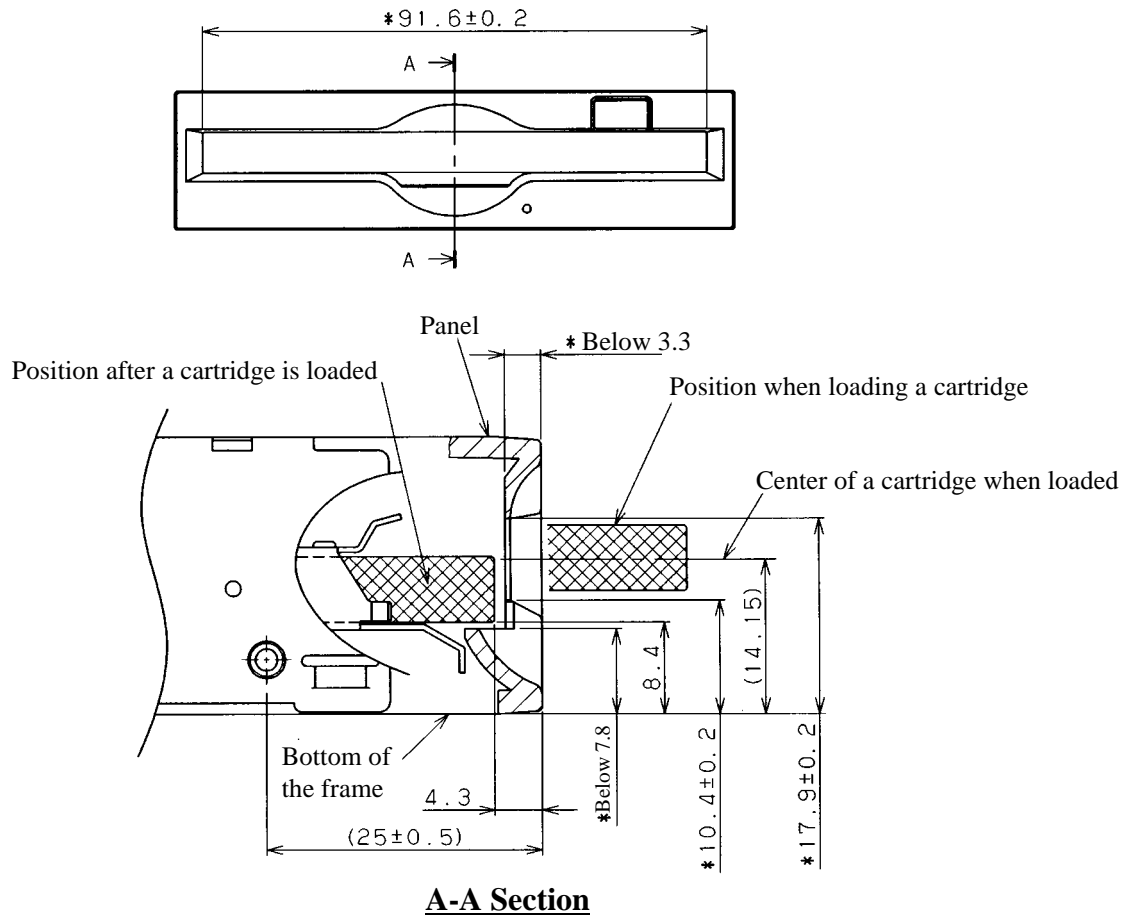

Figure 3.2 Outer dimensions (1 of 2)



**Figure 3.2 Outer dimensions (2 of 2)**

Notes

1. Fujitsu recommends using the dimensions indicated by asterisks in the above figure for the size of the panel opening.
2. If the specified dimensions are not used, the MO disks might be damaged when a cartridge is loaded.



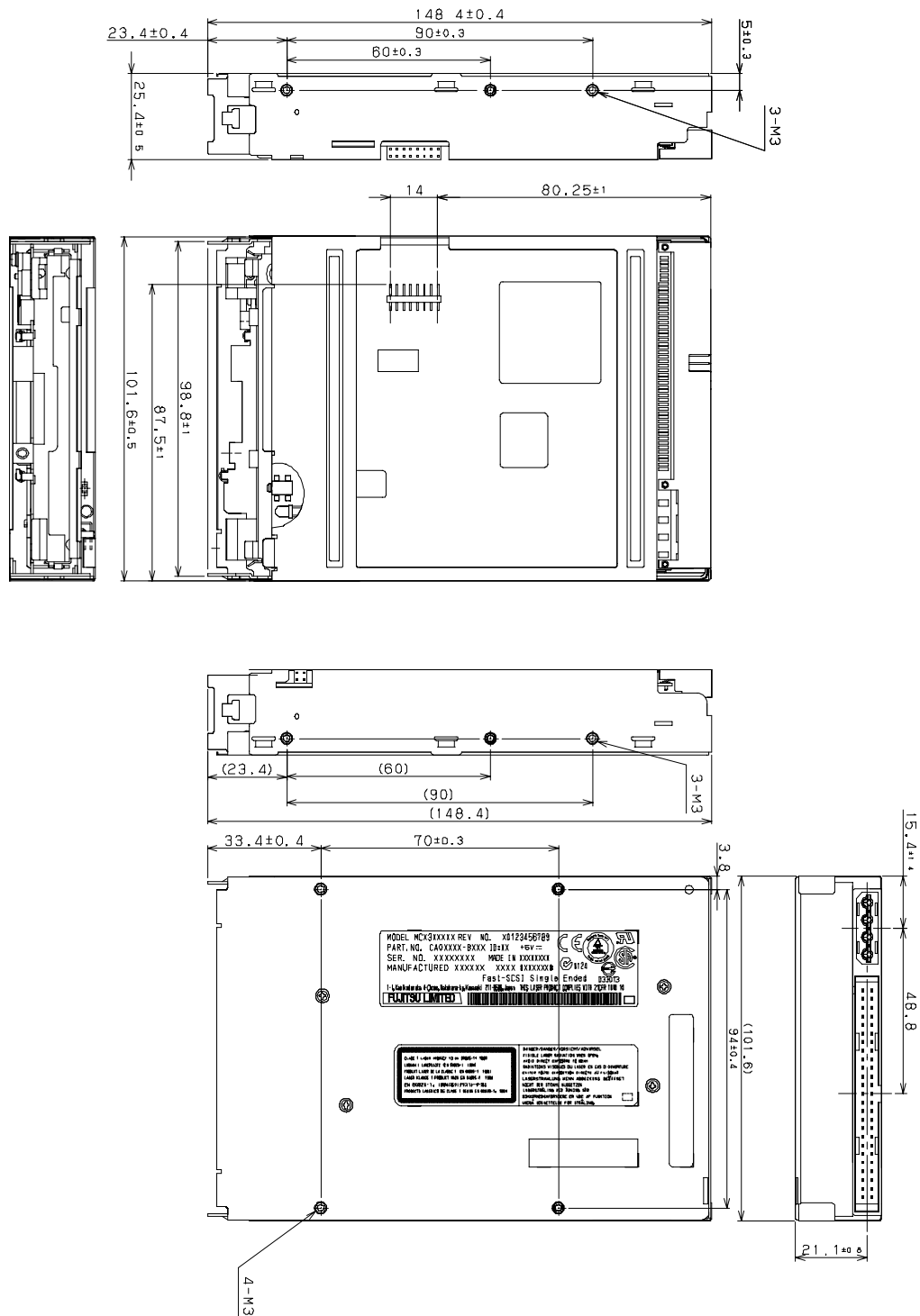

Figure 3.3 Outer dimensions (1 of 3)

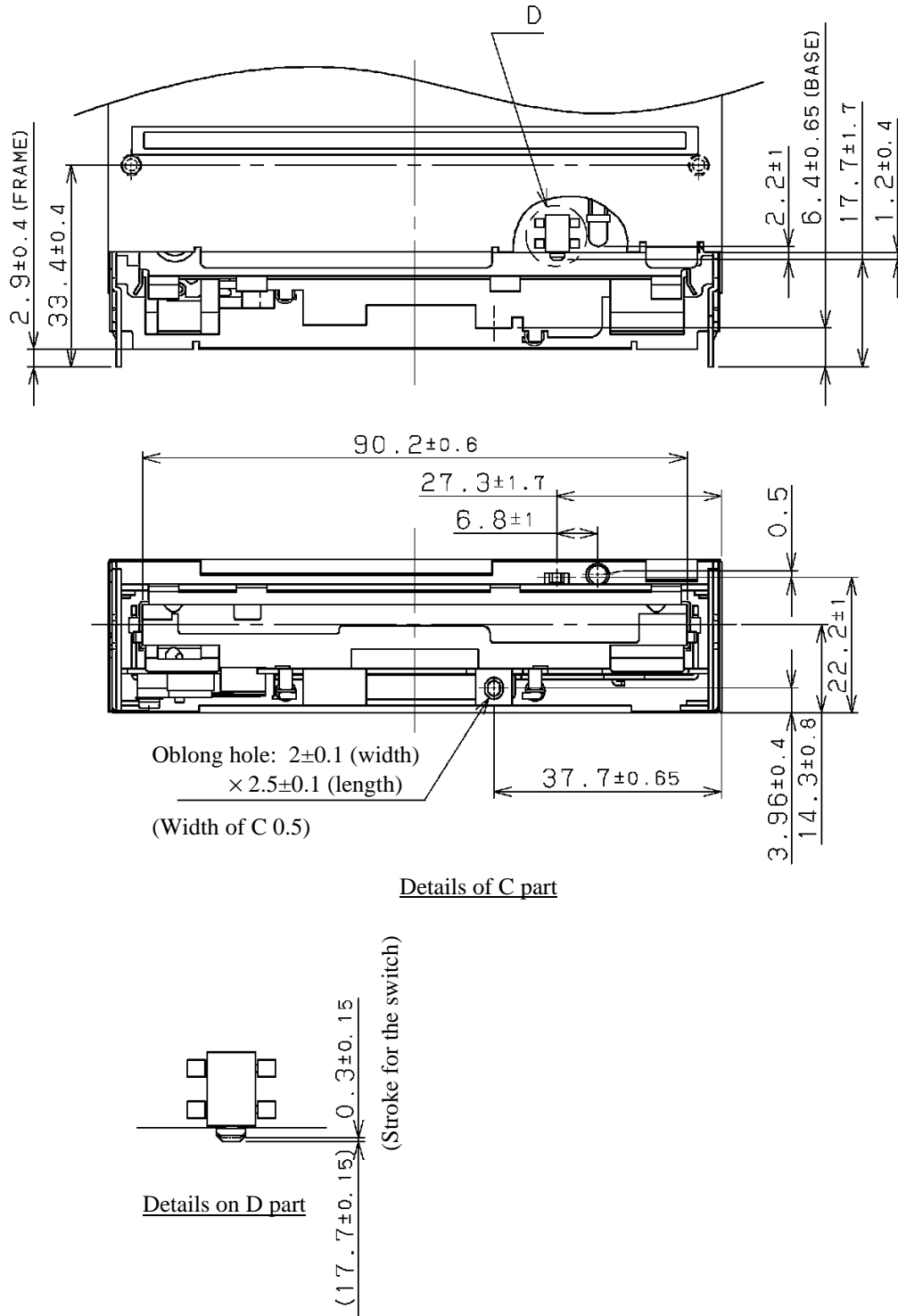

Figure 3.3 Outer dimensions (2 of 3)

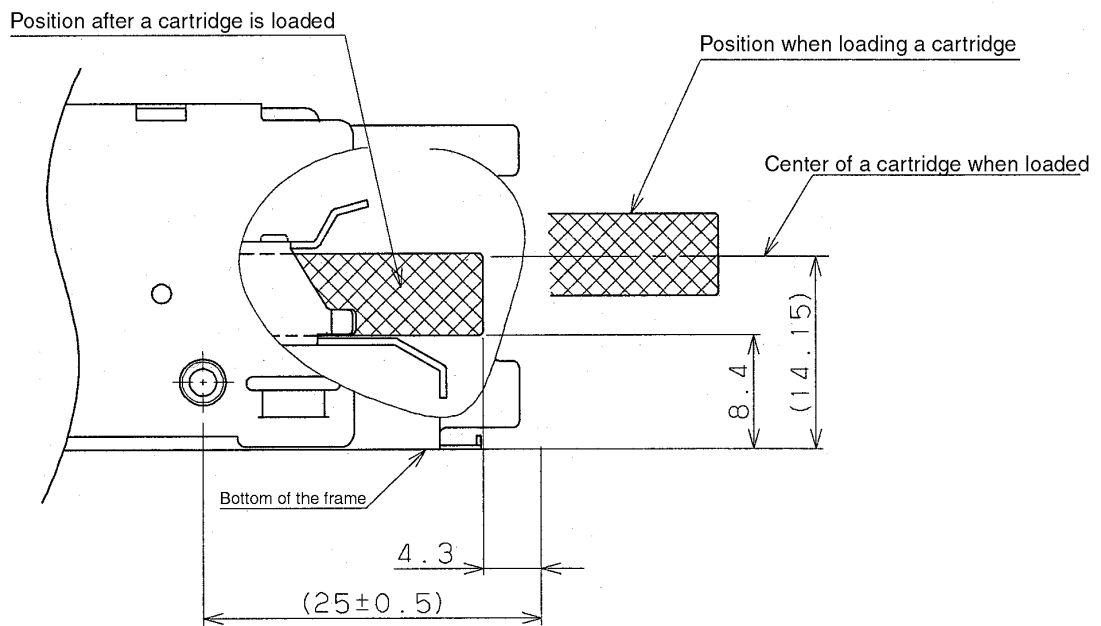
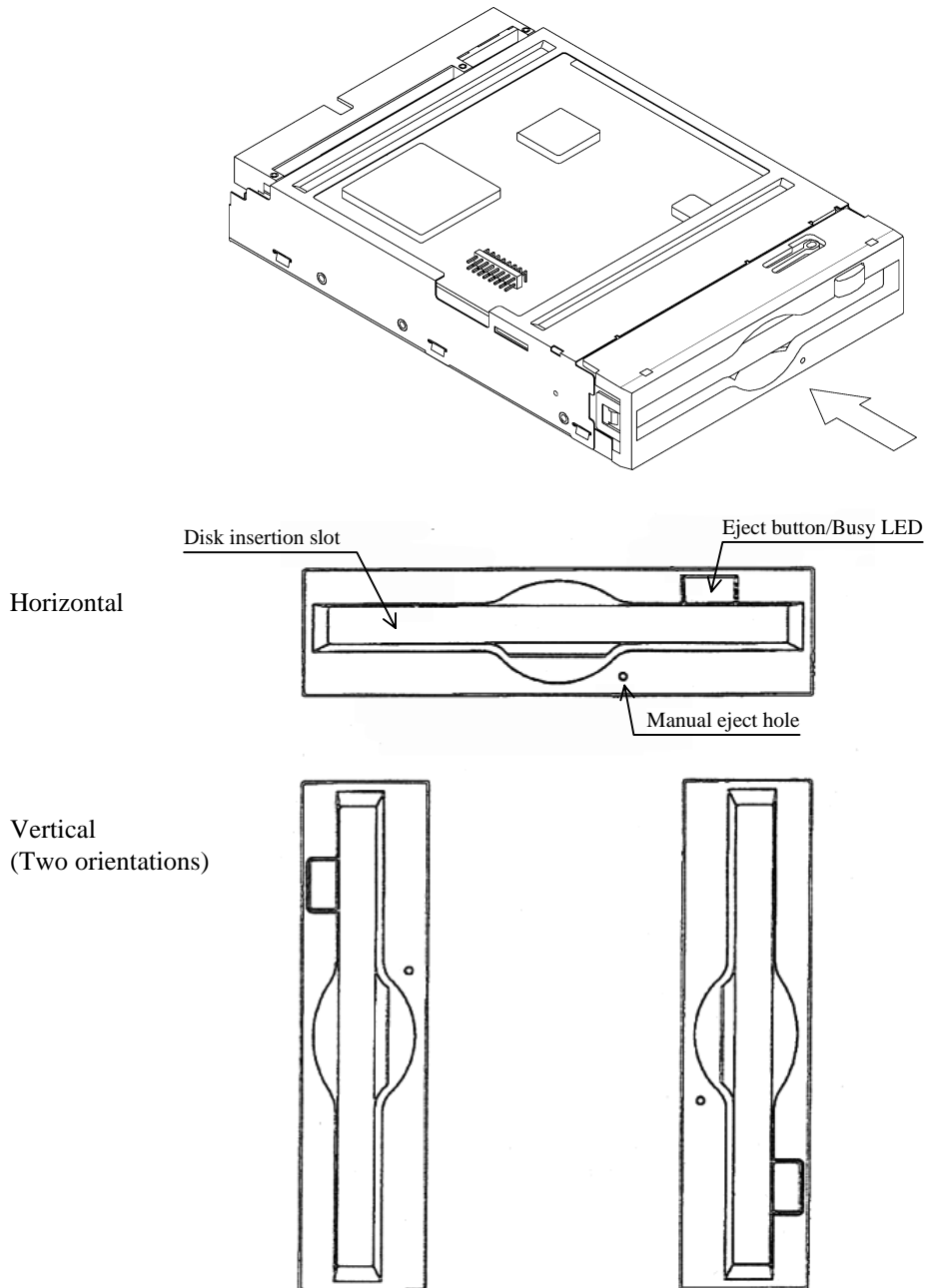

Figure 3.3 Outer dimensions (3 of 3)

### 3.2.2 Installation direction

Figure 3.4 shows the permissible installation directions for the optical disk drive. The mounting angle tolerance must be within  $-5^{\circ}$  to  $10^{\circ}$  relative to the horizontal plane.

(-) shows that the cartridge insertion slot faces downward.



**Figure 3.4 Installation directions**



### 3.2.4 Precautions on mounting

(1) Mounting frame structure and clearance

- a) For vibration resistance and heat dissipation, mount this optical disk drive using a frame having an embossed structure shown in Figure 3.6 or a similar structure providing an equivalent function.
- b) A mounting screw must have an inward projection (entry depth) of 3 mm or less from the outer surface of the mounting frame of the optical disk drive as shown in Figure 3.6.
- c) The upward-downward and left-right clearance between the external surface of the mounting frame of the optical disk drive and the user's emboss-structure frame must be at least 1.5 mm.
- d) The floating clearance of the optical disk drive must be 1.5 mm or more.
- e) When mounting the optical disk drive, the screw tightening torque must be 0.4 to 0.45Nm (4 to 4.6kgf-cm).

If the screw tightening torque exceeds the prescribed value, the unit fixture tap may break, leading to degraded device performance.

- f) When the optical disk drive (with a panel) is mounted in a cabinet, there should be no distortion or deformation in the target housing or the mounting fittings. Furthermore, the optical disk drive's panel must not be deformed.

If the drive is used with the panel deformed, ejection of the cartridge will be faulty.

Make sure that the door closes from any position after mounting the optical disk drive.

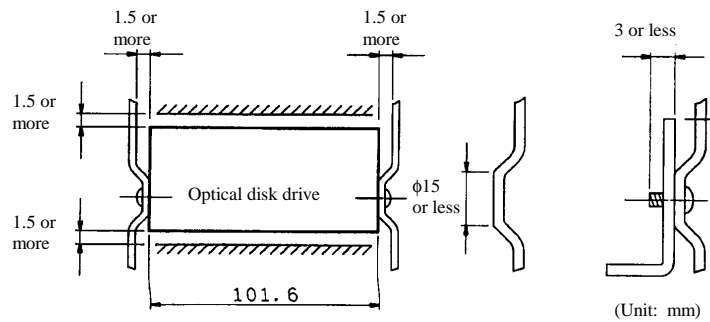

Mounted on the side

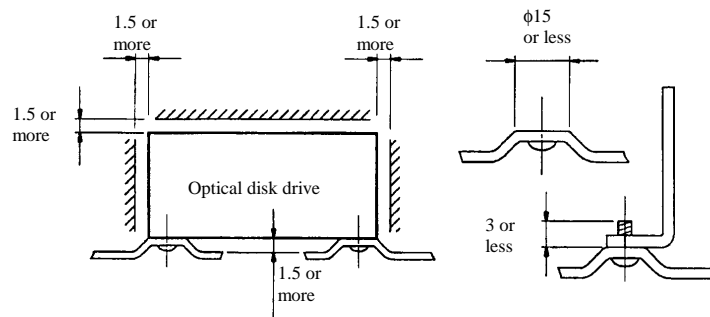

Mounted on the bottom

Figure 3.6 Mounting frame structure

## (2) Checking the panel function

There must not be any deformation in the panel after the optical disk drive is installed in a cabinet. Make sure that the door of the disk insertion slot closes from any location with the drive installed in the cabinet.

## (3) Service areas

Figure 3.7 shows the locations that need to be accessed for installation, and after installation is carried out.

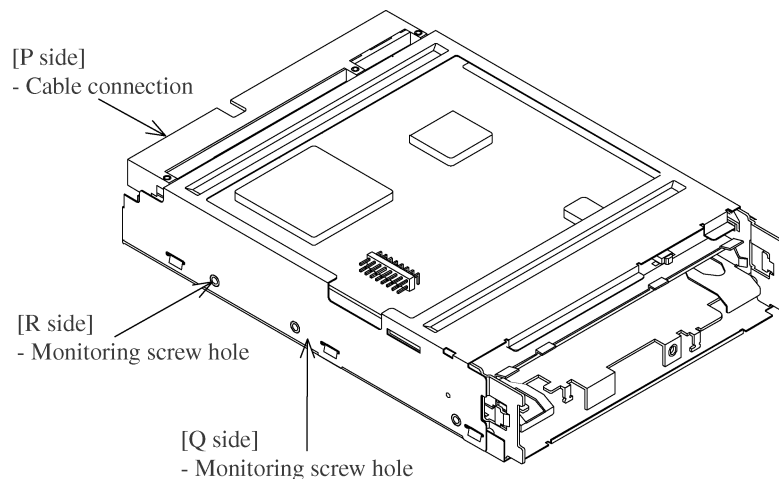

**Figure 3.7 Service areas**

## (4) External magnetic fields

Mount the optical disk drive away from powerful magnetic materials (e.g., a speaker) to avoid any adverse effects from external magnetic fields.

## (5) Leak magnetic field

The VCM drive magnetic circuit may leak a magnetic field (Up to 2.5 mT at a distance of 4 mm from the drive surface).

### IMPORTANT

Do not place any devices sensitive to a magnetic field near the optical disk drive.

## (6) External light source

Mount the optical disk drive away from strong light sources (e.g., camera flash).

## (7) System ground (handling of SG and FG)

The optical disk drive must be grounded to the signal ground (SG) of the power supply of the user's system. This SG line must be supplied with the system as well as the power line.

## IMPORTANT

The optical disk drive can be mounted in a 120 mm (5 inch) device bay of the PC chassis using either a metal frame or a plastic (nonconductive material) frame.

If a plastic frame is used, the personal computer's FG and the optical disk drive's FG are not shorted. Consequently, the static electricity tolerance is inferior to that realized when a metal frame is used.

Fujitsu recommends using a metal frame. In particular, a metal frame must be used especially when high static electricity tolerance is required.

### 3.3 Power Supply Requirements

#### (1) Allowable input voltage and current

The DC power supply input voltage must satisfy the requirements described in Section 2.1.3, "Environmental and power requirements" when measured at the power supply connector pin (receiving end) of the optical disk drive (For other requirements, see items (4) and (5) below).

#### (2) Current waveform (reference)

Figure 3.8 shows the current waveform while a disk is inserted.

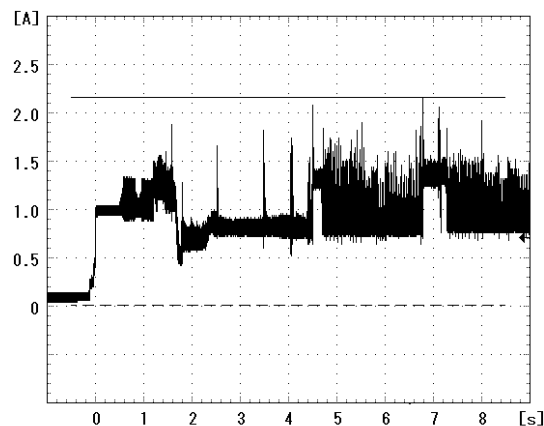
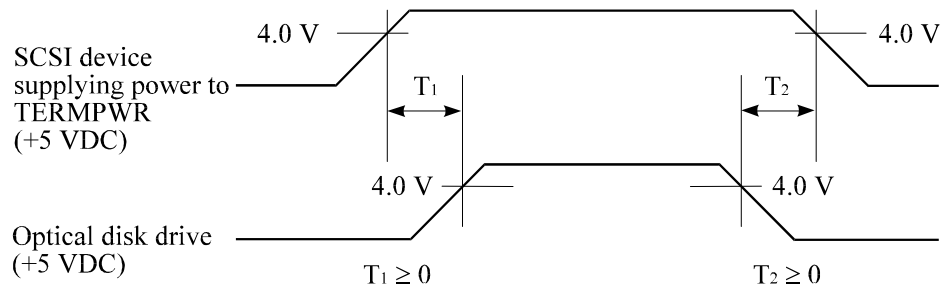

Figure 3.8 MCM3130SS current waveform (+5 VDC)

#### (3) Power on/off sequence

- a) In a system which uses the terminating resistor power supply signal (TERMPWR) of the SCSI bus, the requirements for +5 VDC given in Figure 3.9 must be satisfied between the drive and at least one of the SCSI devices supplying power to that signal.





**Figure 3.9 Power on/off sequence (1)**

- b) In a system which does not use the terminating resistor power supply signal (TERMPWR) of the SCSI bus, the requirements for +5 VDC given in Figure 3.10 must be satisfied between the drive and the SCSI device with the terminating resistor circuit.

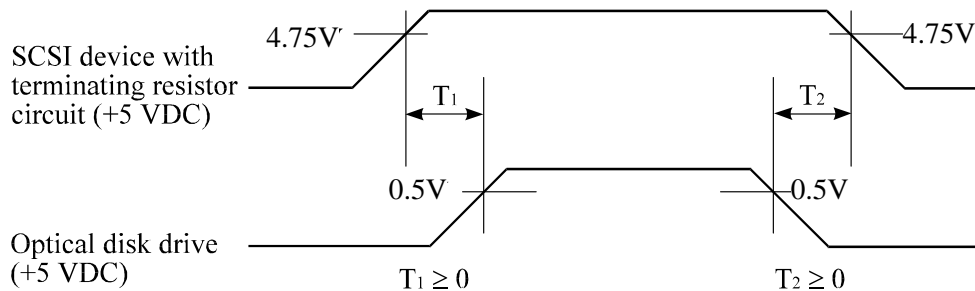
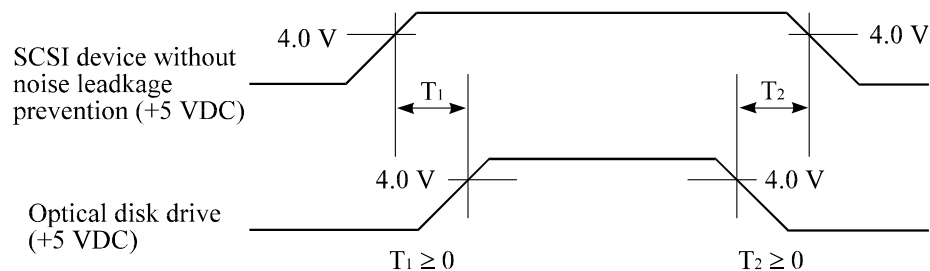

**Figure 3.10 Power on/off sequence (2)**

- c) Between the drive and other SCSI devices on the SCSI bus, the +5 VDC power on/off sequence is as follows:

In a system with all its SCSI devices designed to prevent noise leakage to the SCSI bus when the power is turned on or off, the power sequence does not matter if the requirement in (a) or (b) is satisfied.

In a system containing an SCSI device which is not designed to prevent noise leakage to the SCSI bus, the requirement given in Figure 3.11 must be satisfied between the SCSI device and the drive.



**Figure 3.11 Power on/off sequence (3)**

(4) Power supply to SCSI terminating resistor

If the power for the terminating resistor is supplied from the drive to other SCSI devices through the SCSI bus, the current-carrying capacity of the +5 VDC power supply line to the optical disk drive must be designed with consideration of an increase of up to 900 mA.

Select a method of power supply to the drive in accordance with the setting terminal of the optical disk drive. See Subsection 4.3.3.

(5) Noise filter

To eliminate AC line noise, a noise filter should be installed at the AC input terminal on the power supply unit of the drive. The noise filter specifications are as follows:

Attenuation: 40 dB or more at 10 MHz

Circuit configuration: The T-configuration shown in Figure 3.12.

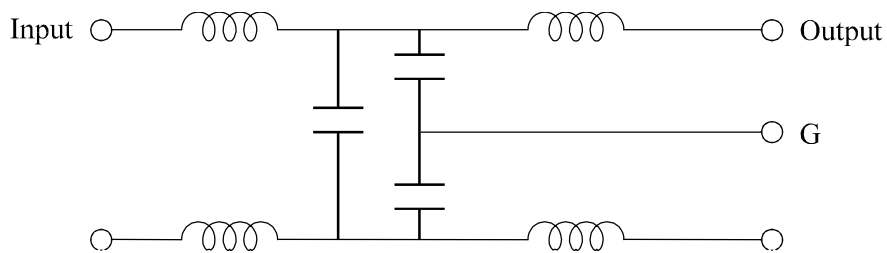

**Figure 3.12 AC noise filter (recommended)**

## 3.4 Connection Requirement

### 3.4.1 Connectors and terminals

This drive is equipped with the connectors and terminals shown below for external connection. Figure 3.13 shows their locations.

Power supply connector

SCSI connector

External operator panel terminal (CNH2)

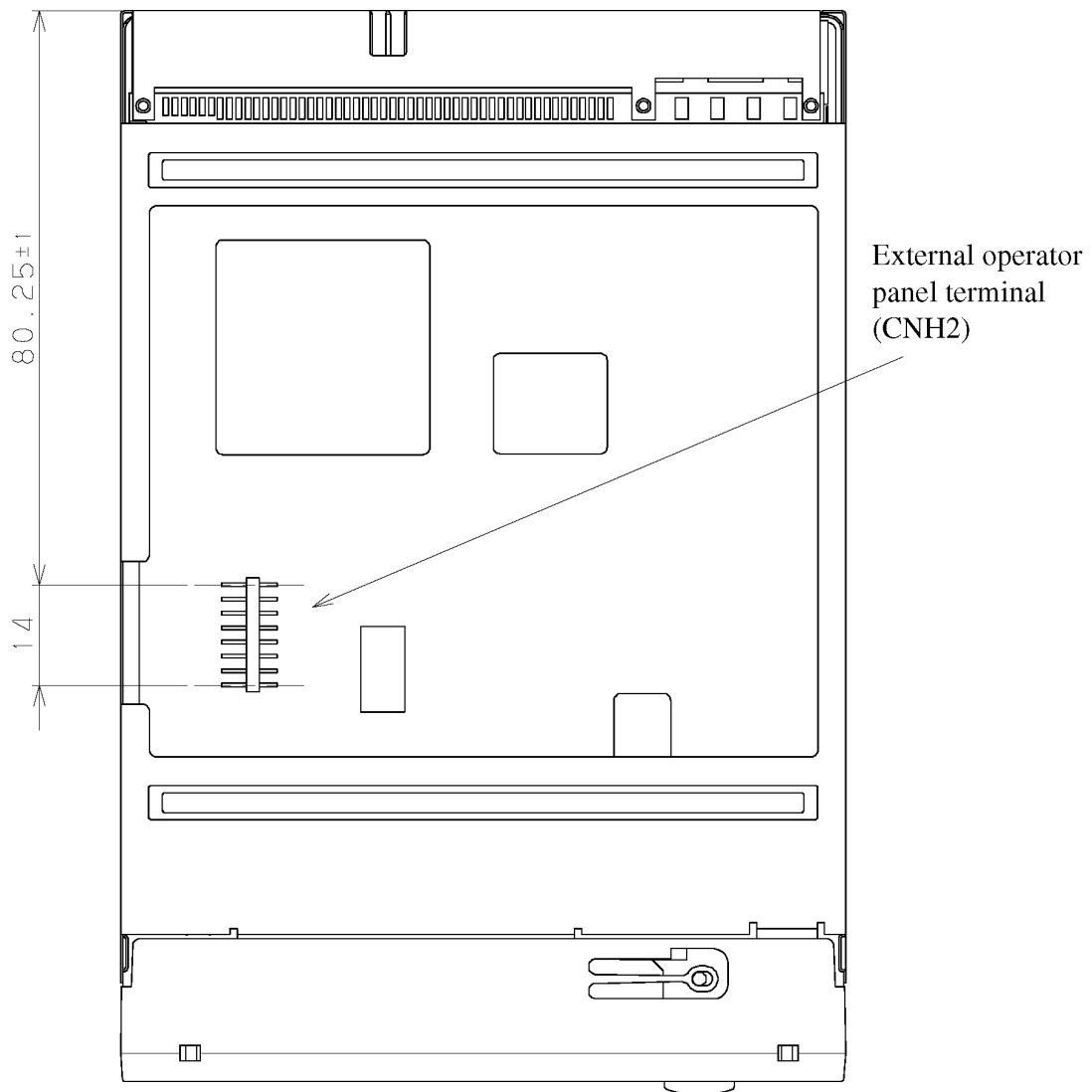

**Figure 3.13** Connector and terminal locations

(1) Power supply connector

Figure 3.14 shows the shape and pin assignment of the DC power supply input connector.

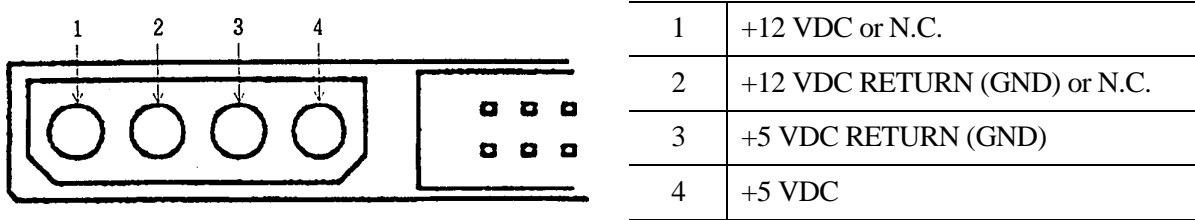

**Figure 3.14** Power supply connector

(2) SCSI connector

The connector for the SCSI bus is an unshielded standard connector with two rows of 25 pins on 2.54 mm centers.

See Chapter 7 for details on the electrical requirements of the interface signals.

**IMPORTANT**

For cables using pin 01 as shield ground, note that the shield of the connector on the drive is not connected to ground.

### 3.4.2 Cable connection requirements

Figure 3.15 shows the cable connection mode between the drive, host system, and power supply unit. Table 3.3 lists recommended components for the connection.

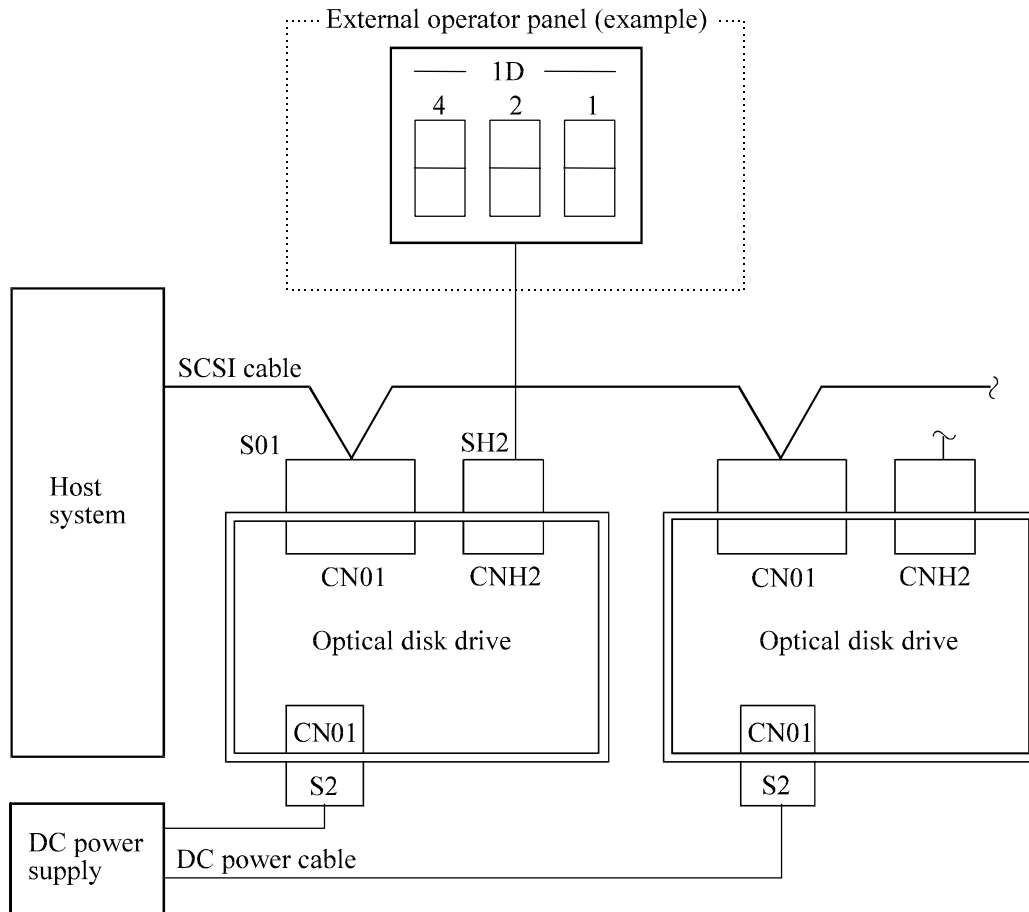

**Figure 3.15** Cable connection mode

**Table 3.3 Recommended components for connection**

Category	Name	Model	Manufacturer	Symbol in Figure 3.15	
SCSI cable	Cable socket (closed-end type)	FCN-707B050-AU/B	Fujitsu Ltd.	S01	
	Cable socket (through-end type)	FCN-707B050-AU/O	Fujitsu Ltd.		
	Signal cable		UL20184-LT25PX28AWG	Hitachi Cable, Ltd.	—
			455-248-50	SPECTRA-STRIP	
Power supply cable	Housing for cable socket	1-480424-0	AMP	S2	
	Contact	170121-4	AMP		
	Cable	AWG18	—	—	
External operator panel	Housing for cable socket	LPC-16F02	Honda-Tsushin	SH2	
	Receptacle	LPC-F104N	Honda-Tsushin		
	Cable	AWG28	—	—	

(1) SCSI cable

A terminating resistor is mounted on the drive when the drive is shipped. A terminating resistor must be disconnected when the drive is not connected to an end of the SCSI cable. Select a method of power supply to the terminating resistor circuit according to the setting pins on the drive. See Section 4.2 for details.

(2) Power supply cable

The drive must be star-chain-connected to the DC power supply unit (one-to-one connection) to reduce the influence of load variations.

### 3.4.3 External operator panel

Some set switch settings can be manipulated through the external operator panel interface.

Figure 3.16 shows a recommended circuit for the external operator panel. Since an external operator panel is not provided as an option, the user must design one based on the system requirements and the recommended circuit.

**IMPORTANT**

Provide switches and LEDs (required for the system) on the external operator panel. See the recommended circuit shown in Figure 3.21. A signal which is not set on the external operator panel connected to CNH2 must be set using SW1. The SW1, and CNH1 corresponding to the signal set on the external operator panel must be set to OFF position.

For details, see Subsection 4.3.1.

Figure 3.17 shows the external operator panel connector and Table 3.4 shows the specification of the external operator panel connector interface.

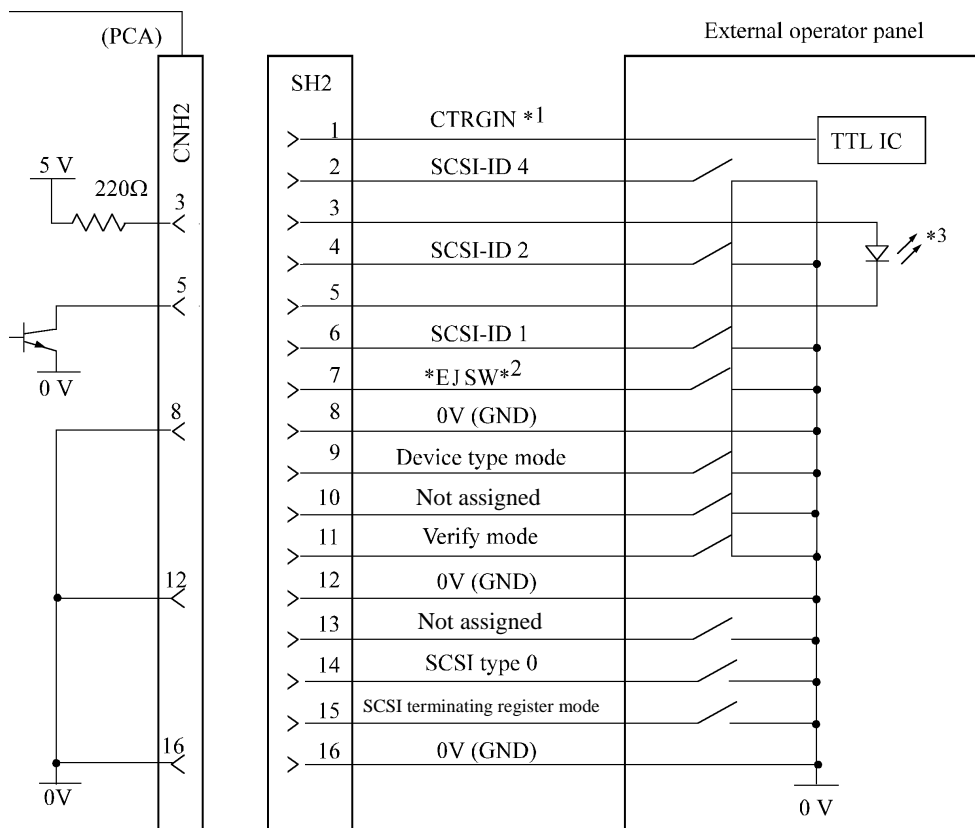

\*1: This signal indicates that the cartridge is in drive.  
H; Exist L: None (TTL level signal)

\*2: This signal is used for ejecting the cartridge from the host system

\*3: For the LED, the following specification must be satisfied.  
Format current: 20 mA or less

Note: The cable length must not exceed 30 cm.

**Figure 3.16 External operator panel circuit example**

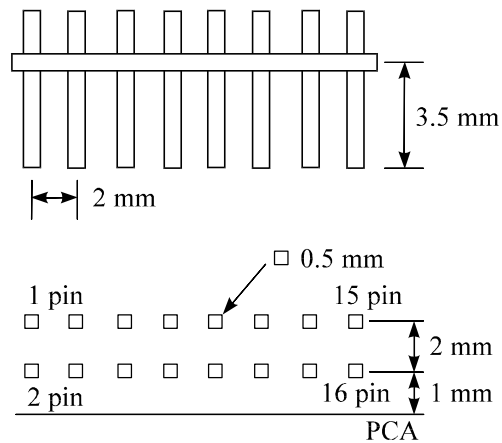

**Figure 3.17 External operator panel interface connector**

**Table 3.4 External operator panel interface**

Signal	Pin	Reference setting signal	Function
SCSI-ID 4	2	SW1-01	Equivalent to ON position of SW1-01 by shorting with 0 V.
SCSI-ID 2	4	SW1-02	Equivalent to ON position of SW1-02 by shorting with 0 V.
SCSI-ID 1	6	SW1-03	Equivalent to ON position of SW1-03 by shorting with 0 V.
Device type mode	9	SW1-06	Equivalent to ON position of SW1-06 by shorting with 0 V. See 3.4.4 (1)
Not assigned	10	–	–
Verify mode	11	–	See 3.4.4 (3)
Not assigned	13	–	–
SCSI type-0	14	–	See 3.4.4 (5)
SCSI terminating resistor mode	15	CNH1(5-6)	Equivalent to shorting CNH1 05-06 by shorting with 0 V.
+LED	3	–	LED+terminal for external connection
–LED	5	–	LED–terminal for external connection
*EJSW	7	–	External eject instruction input (TTL-IC level) L level: Equivalent to pushing eject switch H level: Equivalent to not pushing eject switch
CTRGIN	1	–	External cartridge sensor output (TTL-IC level) L level: No cartridge in drive H level: Cartridge in drive
0 V (GND)	8, 12, 16	–	0 V



### 3.4.4 External operator panel settings (CNH2)

#### (1) Device type mode

Table 3.5 shows the device type settings which are returned when the INQUIRY command is issued to the optical disk drive.

**Table 3.5 Device type mode setting**

Device Type	CNH 2/Pin 9 - GND
X'07' (Optical memory device)	Short
X'00' (Direct access device)	Open *

\* Setting when shipped

#### (2) Verify mode

The default setting of the verify function is specified. When the verify mode is invalid, verification is not performed when the WRITE command is issued. With the verification invalid, the writing speed is increased by about 20% (depending on the situation). Table 3.6 shows the verify mode settings. The verification can also be specified as valid or invalid by the MODE SELECT command.

**Table 3.6 Write verify mode setting**

Write verify mode	CNH 2/Pin 11 - GND
Does not perform verification for the WRITE command (invalid)	Short
Performs verification for the WRITE command (valid).	Open*

\* Setting when shipped

## **⚠ CAUTION**

**Data loss:** When the verify function is invalid, the write data quality is not guaranteed. This mode should not be used for storing important data. When using the mode for storing important data, a preventive system measure such as file duplication is required.

(3) SCSI type 0

The command specification and message specification are specified. The SCSI-1 specification is compatible with that of the old unit (M2511A). Table 3.7 shows the command and message specification settings.

**Table 3.7 Logical specification type setting**

Command specification and message specification	CNH 2/Pin 14 - GND
SCSI-2 specification	Open*
SCSI-1 specification	Short

\* Setting when shipped

# CHAPTER 4 Installation

4.1	Notes on Drive Handling
4.2	Connection Modes
4.3	Settings
4.4	Mounting
4.5	Cable Connections
4.6	Operation Confirmation and Preparation for Use after Installation
4.7	Dismounting Drive

This chapter describes notes on handling the drives, connection modes, settings, mounting the drives, cable connections, and operation confirmation and preparation for use after installation, and notes on demounting the drives.

## 4.1 Notes on Drive Handling

### (1) General notes

Note the following points to maintain drive performance and reliability:

#### **▲ CAUTION**

- 1) Shock or vibration applied to the drive that exceeds the values defined in the standard damage the drive. Use care when unpacking.
- 2) Do not leave the drive in dirty or contaminated environments.
- 3) Since static discharge may destroy the CMOS devices in the drive, pay attention to the following points after unpacking:
  - Use an antistatic mat and wrist strap when handling the drive.
  - Hold the mounting frame when handling the drive. Do not touch the PCA except when setting the switches.
- 4) When handling the drive, hold both sides of the mounting frame. When touching other than both sides of the mounting frame, avoid putting force.
- 5) Do not forcibly push up the end of the header pin of the printed circuit board unit when handling or setting the drive.

### (2) Unpackaging

- a) Make sure that the UP label on the package is pointing upward and start unpacking on a level surface. Handle the drive on a soft surface such as a rubber mat, not on a hard surface such as a desk.

- b) Use care to avoid exerting excessive pressure on the unit when removing the cushions.
- c) Use care to avoid exerting excessive pressure on the PCA surface and interface connectors when removing the drive from the antistatic bag.
- d) If the temperature difference between installation locations is 10 degrees or more, leave the drive in the new location for at least two hours before unpackaging it.

(3) Installation

- a) Do not connect or disconnect the connectors or change the terminal settings when the power is on.
- b) Do not move the drive with the power on.
- c) Eject the optical disk cartridge, lock the carriage securing the head, turn off the power, then move the drive.

**▲ CAUTION**

Before moving the drive, remove the optical disk cartridge. If the drive is moved with the optical disk cartridge loaded in it, the head may move back and forth in the drive to damage the head or disk and reading the data may fail.

(4) Packaging

- a) Before packaging, remove the optical cartridge.
- b) Store the drive in an antistatic plastic bag with desiccant (silica gel).
- c) Use the same cushions and packaging supplied with the drive. If they are not available, ensure that adequate shock absorbent material is used. In this case, some method of protecting the PCA surface and interface connectors must be used.
- d) Ap "UP" and "Handle With Care" labels to the outside of the package.

Figure 4.1 shows the individual packaging style and Figure 4.2 shows the gathered packaging style. (The form and material of the cushion may be changed.)

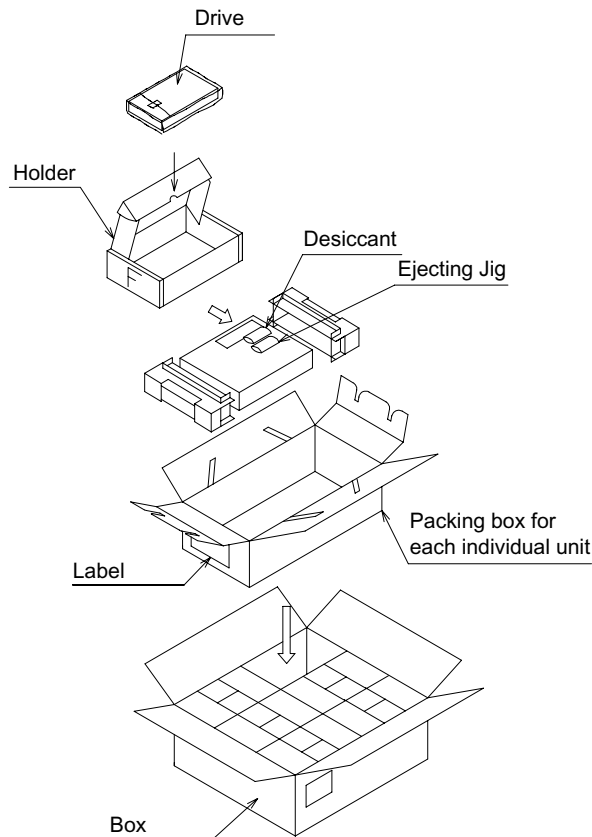

Figure 4.1 Individual packaging style

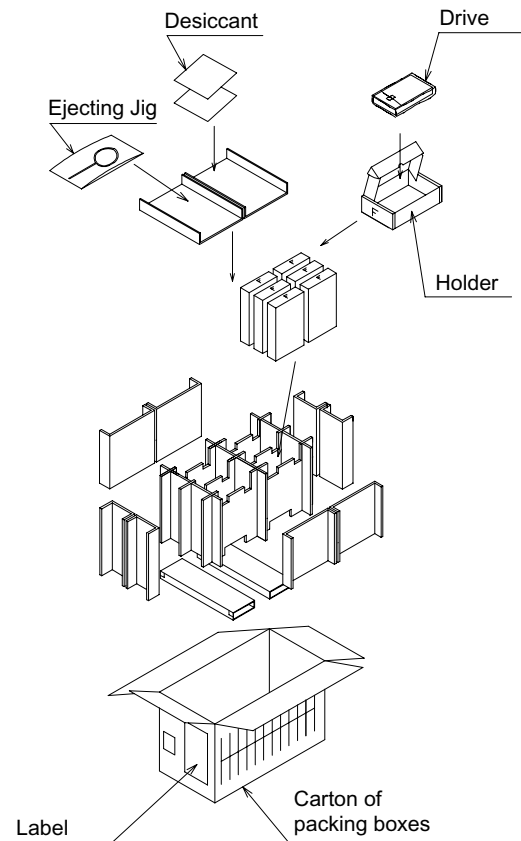

Figure 4.2 Gathered packaging style

## (5) Transportation

- a) Transport the package with the UP sign upward.
- b) After unpacking, minimize the transportation distance and use cushions to avoid shock and vibration. Transport the drive in one of the orientations described in Subsection 3.2.2 after unpacking. (The horizontal direction is recommended.)

## (6) Storage

- a) Use moistureproof packaging when storing the drive.
- b) The storage environment must satisfy the requirements specified in Subsection 2.1.3 when the drive is not operating.
- c) To prevent condensation, avoid sharp changes in temperature.

## 4.2 Connection Modes

Figure 4.3 shows examples of connections between the host system and the optical disk drive. Up to eight devices including the host adapter, optical disk drive, and other SCSI equipment can be connected to the SCSI bus in arbitrary combinations. Install a terminating resistor on the SCSI devices connected to either end of the SCSI cable.

See Section 3.4 for the cable connection requirements and power cable connections.

(a) Connecting one optical disk drive

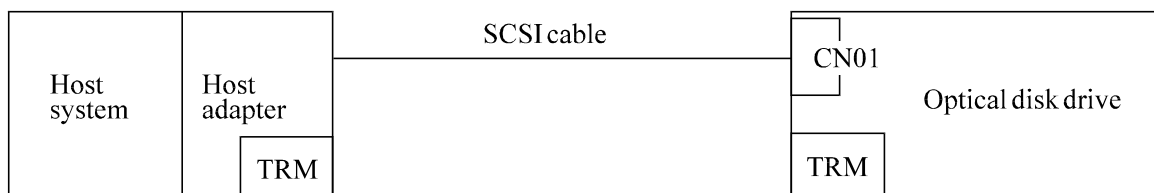

(b) Connecting more than one optical disk drive (single host)

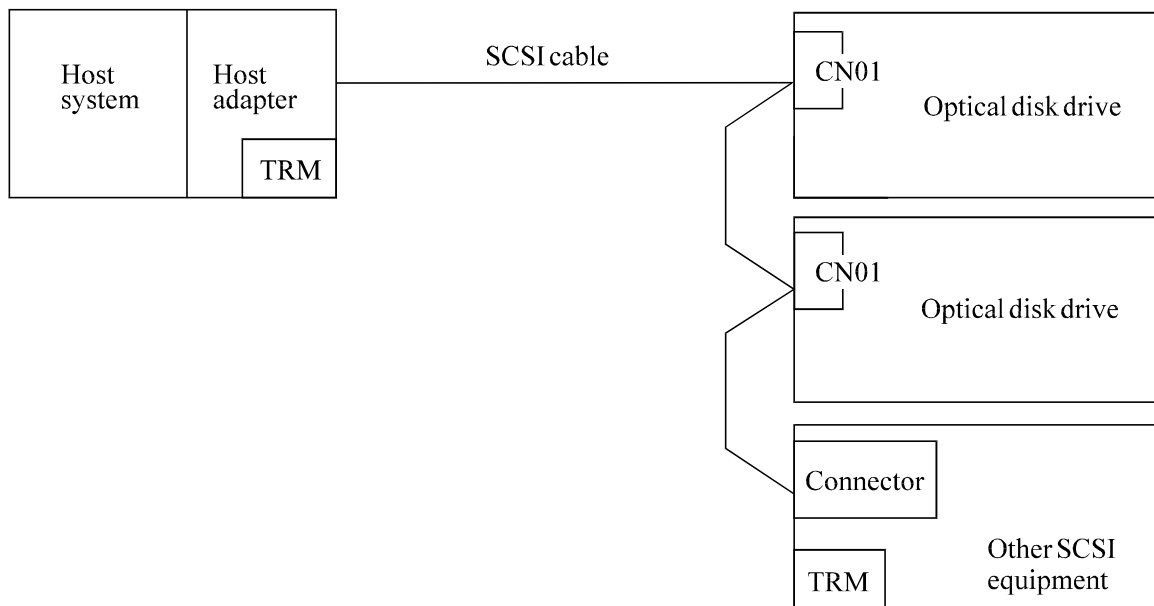
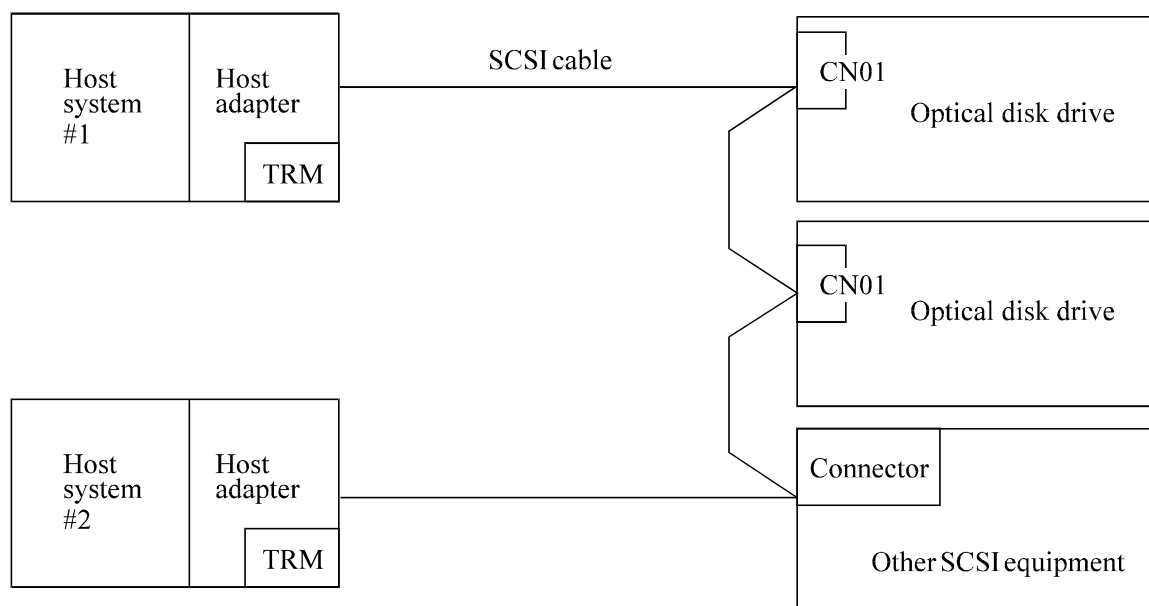

Figure 4.3 SCSI bus connection modes (1 of 2)

## (c) Connecting more than one optical disk drive (multi-host)



**TRM** : SCSI terminating resistor

**Connector** : Interface connector

**Figure 4.3 SCSI bus connection modes (2 of 2)**

## 4.3 Settings

Before installing the drive in the system, set the following setting terminal, setting switches, and SCSI terminating resistors:

- Setting terminal : CNH1
- Setting switches : SW1

Figure 4.4 shows the positions of the setting terminal and switch.

### **CAUTION**

- 1) The user must not change the settings of terminals not described in this section. The terminals must remain as set when shipped.
- 2) Do not change terminal settings when the power is on.
- 3) To strap setting terminals, use the jumper shipped with the drive.

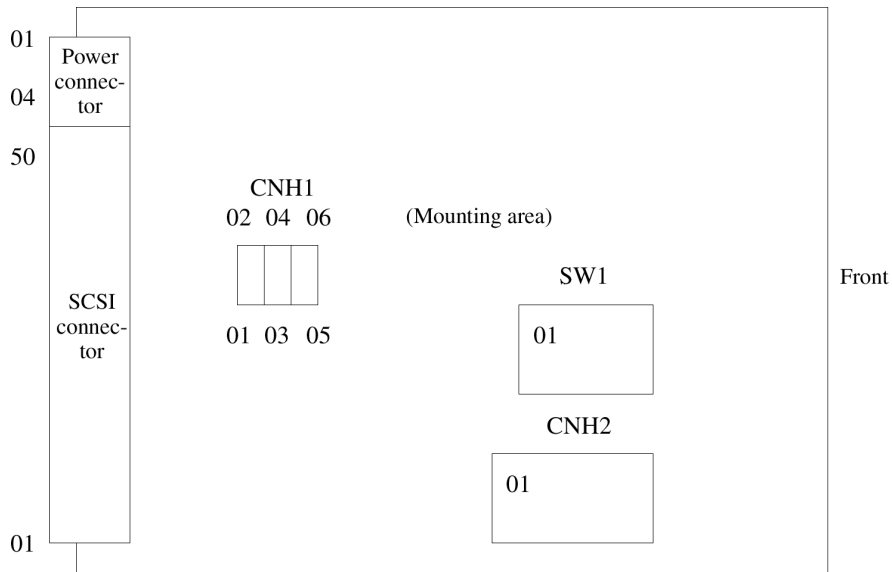

**Figure 4.4 Positions of setting terminals and switches**

Setting items are as follows:

- SW1
  - SCSI ID
  - SCSI data bus parity check
  - Write cache mode
  - Device type mode
  - Spindle automatic stop mode
  - Factory test mode (user setting inhibited)
- CNH1
  - SCSI terminating resistor power supply
  - SCSI terminating resistor mode
- CNH2
  - SCSI ID
  - Device type mode
  - Verify mode
  - SCSI type-0
- SCSI connector
  - SCSI signal
- Power connector
  - +5VDC
  - GND



### 4.3.1 Setting switches (SW1)

Figure 4.5 shows the types of switches and their settings when the drive was shipped.

- SW1

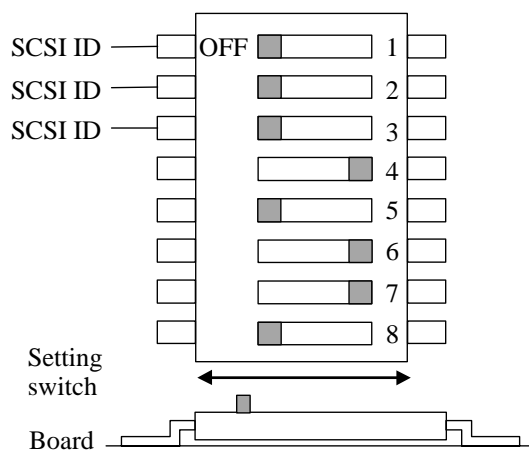

	Switch number	Signal name	At shipment
SW1	01	SCSI ID	OFF
	02		OFF
	03		OFF
	04	SCSI data bus parity check	ON
	05	Write cache mode	OFF
	06	Device type mode	ON
	07	Spindle automatic stop mode	ON
	08	Factory test mode (user setting inhibited)	OFF

**Figure 4.5 Setting switch (SW1)**

(1) SCSI ID

Table 4.1 shows the SCSI ID settings of the drive.

**Table 4.1 SCSI ID setting (SW1)**

SCSI ID	SW1-01	SW1-02	SW1-03
0 (*1)	OFF	OFF	OFF
1	OFF	OFF	ON
2	OFF	ON	OFF
3	OFF	ON	ON
4	ON	OFF	OFF
5	ON	OFF	ON
6	ON	ON	OFF
7	ON	ON	ON

\*1 Setting when shipped

**IMPORTANT**

- 1) Each SCSI device connected to the same SCSI bus must have a unique SCSI ID.
- 2) If contention occurs in the ARBITRATION phase, the priority of the SCSI use authority depends on SCSI IDs as follows:  
7 > 6 > 5 > 4 > 3 > 2 > 1 > 0

(2) SCSI data bus parity checking

Table 4.2 shows the settings which determine whether to check the SCSI bus parity bit. Regardless of the settings, the parity bit is ensured for data transmitted by the drive.

**Table 4.2 SCSI data bus parity checking (SW1)**

SCSI data bus parity checking by drive	SW1-04
Checked	ON (*1)
Not checked	OFF

\*1 Setting when shipped

## (3) Write cache mode

The write cache mode can be set. The write cache mode can also be enabled or disabled by the MODE SELECT command.

When the write cache mode is enabled, the cache control page is added to the code page of the mode parameter even if the SCSI-1 is set. Table 4.3 shows the settings of the write cache mode.

**Table 4.3 Write cache mode setting**

Write cache mode	SW1-05
Write cache is enabled at executing the WRITE/WRITE AND VERIFY command.	ON
Write cache is disabled at executing the WRITE/WRITE AND VERIFY command	OFF (*1)

\*1 Setting when shipped

**IMPORTANT**

When the write cache feature is enabled, a write error is reported at the completion status of next command. At a system so that the initiator retries the command, a retry process may be failed.

## (4) Device type mode

The device type settings, which are returned when the INQUIRY command is issued to the optical disk drive, are shown below.

**Table 4.4 Device type mode settings**

Device type	Setting terminal (SW1-06)
X'00' (Direct access device)	OFF
X'07' (Optical memory device)	ON (*1)

\*1 Setting when shipped

## (5) Spindle automatic stop mode

Normally, with the cartridge loaded, the spindle rotation is maintained until the spindle is instructed to stop by the START/STOP UNIT command. The spindle auto stop function automatically stops the spindle after the command has not been issued from the host for about 33 minutes (default value). When the command is issued from the host with the spindle automatically stopped, the optical disk drive turns the spindle again and performs processing in the same manner as in a ready state without posting a not ready state.

The access supervision time from the host is about 33 minutes as the default. However, it can be changed by the MODE SELECT command.

The spindle auto stop mode can also be changed by the MODE SELECT command.

Table 4.5 shows spindle auto stop mode setting.

**Table 4.5 Spindle automatic stop mode setting**

Spindle auto stop	SW1-07
The spindle motor automatically stops.	ON (*1)
The spindle motor does not automatically stop.	OFF

\*1 Setting when shipped

**IMPORTANT**

The characteristic of the spindle auto stop function are as follows:

- Reduces the deposition of dust which could cause a cartridge error.
- Not suitable for a system requiring quick response because it takes a few seconds to start the spindle.

**4.3.2 Setting of supplying power to SCSI terminating resistor**

Table 4.6 shows how to supply power to the SCSI terminating resistor module on the drive and how to use TERMPWR lines on the SCSI bus.

**Table 4.6 SCSI terminating resistor power supply (CNH1)**

SCSI terminating resistor power supply	CNH1 01-02	CNH1 03-04
Power is supplied from both of the drive and TERMPWR pin.	Short (*1)	Short (*1)
Power is supplied from the drive only. (TERMPWR pin is not used)	Short	Open
Power is supplied from TEMPWR pin only. (Drive's power supply is not used)	Open	Short
No power is supplied.	Open	Open

\*1 Setting when shipped

### 4.3.3 SCSI terminating resistor mode

Enabling or disabling the SCSI terminating resistor, module on the PCA can be set.

When the drive positions at other than the end of the SCSI bus, the SCSI terminating resistor should be disabled. Table 4.7 shows the SCSI terminating resistor mode setting.

**Table 4.7 SCSI terminating resistor mode (CNH1)**

SCSI terminating resistor mode	CNH 1 05-06
SCSI terminating resistor module on the PCA is enabled.	Short (*1)
SCSI terminating resistor module on the PCA is disabled.	Open

\*1 Setting when shipped

Note:

Open CNH1 5-6 pins when the SCSI terminating resistor set by CHN 2-15 pin.

## 4.4 Mounting

### 4.4.1 Checks before mounting the drive

Before mounting the optical disk drive in the system cabinet, check whether the setting switches and terminals are set correctly.

Table 4.8 shows the checklist.

**Table 4.8 Setting checklist**

Setting switch	Setting item	Setting on:	Default	Check
	1 SCSI ID	SW1-01 SW1-02 SW1-03	OFF OFF OFF	(SCSI ID=__) <input type="radio"/> OFF <input type="radio"/> ON <input type="radio"/> OFF <input type="radio"/> ON <input type="radio"/> OFF <input type="radio"/> ON
	2 SCSI data bus parity check	SW1-04	ON	<input type="radio"/> OFF <input type="radio"/> ON
	3 Write cache mode	SW1-05	OFF	<input type="radio"/> OFF <input type="radio"/> ON
	4 Device type mode	SW1-06	ON	<input type="radio"/> OFF <input type="radio"/> ON
	5 Spindle automatic stop mode	SW1-07	ON	<input type="radio"/> OFF <input type="radio"/> ON
	6 Factory test mode (user setting inhibited)	SW1-08	OFF	<input type="radio"/> OFF <input type="radio"/> ON

CNH1	Setting item	Setting on:	Default	Check
	1 Supplied from both ODD and TERMPWR pin.	CNH1 1-2 CNH1 3-4	Short Short	<input type="radio"/> Short <input type="radio"/> Open <input type="radio"/> Short <input type="radio"/> Open
	2 Supplied from ODD	CNH1 1-2 CNH1 3-4	Short Short	<input type="radio"/> Short <input type="radio"/> Open <input type="radio"/> Short <input type="radio"/> Open
	3 Supplied from TERMPWR pin.	CNH1 1-2 CNH1 3-4	Short Short	<input type="radio"/> Short <input type="radio"/> Open <input type="radio"/> Short <input type="radio"/> Open

Terminating resistor	Check item	Check
	1 Drive location on SCSI bus	<input type="radio"/> Other than end <input type="radio"/> Either end
2 SCSI terminating resistor mode (CNH1 5-6)	<input type="radio"/> Open <input type="radio"/> Short	

### 4.4.2 Mounting procedure

How the drive is mounted depends on the system cabinet structure. Determine the mounting procedure in consideration of the requirements of each system. This section contains the general mounting procedure and check items.

See Section 3.2 for details on mounting drive.

- 1) For a system with an external operator panel mounted, connect the external operator panel cable before mounting the drive in the system cabinet because it is difficult to access the connector after the drive is mounted.
- 2) Tighten four mounting screws to secure the drive in the system cabinet.

The drive has ten mounting holes (both sides: 3×2, bottom: 4). Secure the drive using the four mounting holes on both sides or the bottom.

Use mounting screws whose lengths are 3 mm or less from the external wall of the mounting frame of the drive when they are tightened. (See Figure 3.6)

When mounting with screws, the screw tightening torque should be 0.4 to 0.45Nm (4 to 4.6kgf-cm).

Be careful not to damage the parts on the PCA when mounting the drive.

- 3) After securing the drive, make sure that the drive does not touch the chassis of the system cabinet. There must be at least 1.5 mm clearance between the drive and chassis. (See Figure 3.6)

## 4.5 Cable Connections

Use the following cables to connect the drive to the system. See Subsection 3.4.2 for details on the connector positions and cable requirements.

- Power supply cable
- SCSI cable
- External operator panel cable (if required)

The general procedure for cable connection and notes on connecting cables are given below. Pay attention to the insertion direction of each cable connector.



- 1) Make sure that the system power is off.
  - 2) Do not connect or disconnect any cable when the power is on.
- 1) Connect the power cable.
  - 2) Connect the external operator panel (only if required for the system).
  - 3) Connect the SCSI cable.

- 4) After each cable connector is connected, secure the cable so that the cable does not touch the drive or the parts on the PCA or obstruct the flow of cooling air in the system cabinet.

### **CAUTION**

- 1) Be careful of the insertion directions of SCSI connectors. For a system in which the terminating resistor power is supplied via the SCSI cable, connecting connectors in the wrong direction may cause the following:  
The overcurrent protection fuse of the terminating resistor power supply (SCSI device) may blow when power is turned on.  
The cable may burn if overcurrent protection is not provided.
- 2) Be careful of cable connector positions when connecting more than one SCSI device. The SCSI device having the terminating resistor must be connected to the end of the cable.
- 3) The cables must be kept away from the rotating part of the spindle motor.

## **4.6 Operation Confirmation and Preparation for Use after Installation**

### **4.6.1 Confirming initial operations**

This section provides the operation check procedures after the power is turned on.

#### (1) Initial operation when the power is turned on

- When the power is turned on, the drive starts initial self-diagnosis. The LED on the front panel is on for 1 second during initial self-diagnosis.
- If an error is detected during initial self-diagnosis, the LED on the front panel blinks.
- In case of not inserted the cartridge, when the power is turned on, the eject motor automatically turns once.

#### (2) Checks if errors occur at initial self-diagnosis

- Make sure that the cables are connected correctly.
- Make sure that the supply voltage is correct. (Measure the voltage at the power supply connector of the optical drive.)
- Make sure that the settings of all terminals are correct.
- If the LED on the front panel blinks continuously, an error was detected during initial self-diagnosis. In this case, issue the REQUEST SENSE command from the initiator (host system) to obtain sense data for error analysis.



### **IMPORTANT**

The BUSY LED is on while the optical disk drive is executing seek, write, or read operations. The BUSY LED is on momentarily, so it seems as if it blinked or is off.

The eject motor turns once when the power is turned on so that in case the spindle motor position deviates due to shocks received by the drive during transport the position is corrected to allow the cartridge to be inserted normally. If the cartridge fails to be inserted, remove the cartridge and turn on the drive power to turn the eject motor once and reinsert the cartridge.

#### **4.6.2 SCSI connection check**

When initial operation checks out normally after the power is turned on, check whether the drive is correctly connected to the SCSI bus from the host system. Checking the SCSI connection depends on the host system configuration. This section describes the general procedure.

##### (1) Procedure

Figure 4.6 shows the recommended checking procedure.

Note:

Steps a) to c) correspond to a) to c) in Figure 4.6.

- a) Issue the TEST UNIT READY command and check that the drive is connected correctly to the SCSI bus.
- b) Use the WRITE BUFFER and READ BUFFER commands to check whether the SCSI bus operates normally. Use data whose bits change to 0 or 1 at least once. (Example: A X'00' to X'FF'increment pattern)
- c) Check whether the settings are correct. Also, make sure that the controller and drive operate normally.

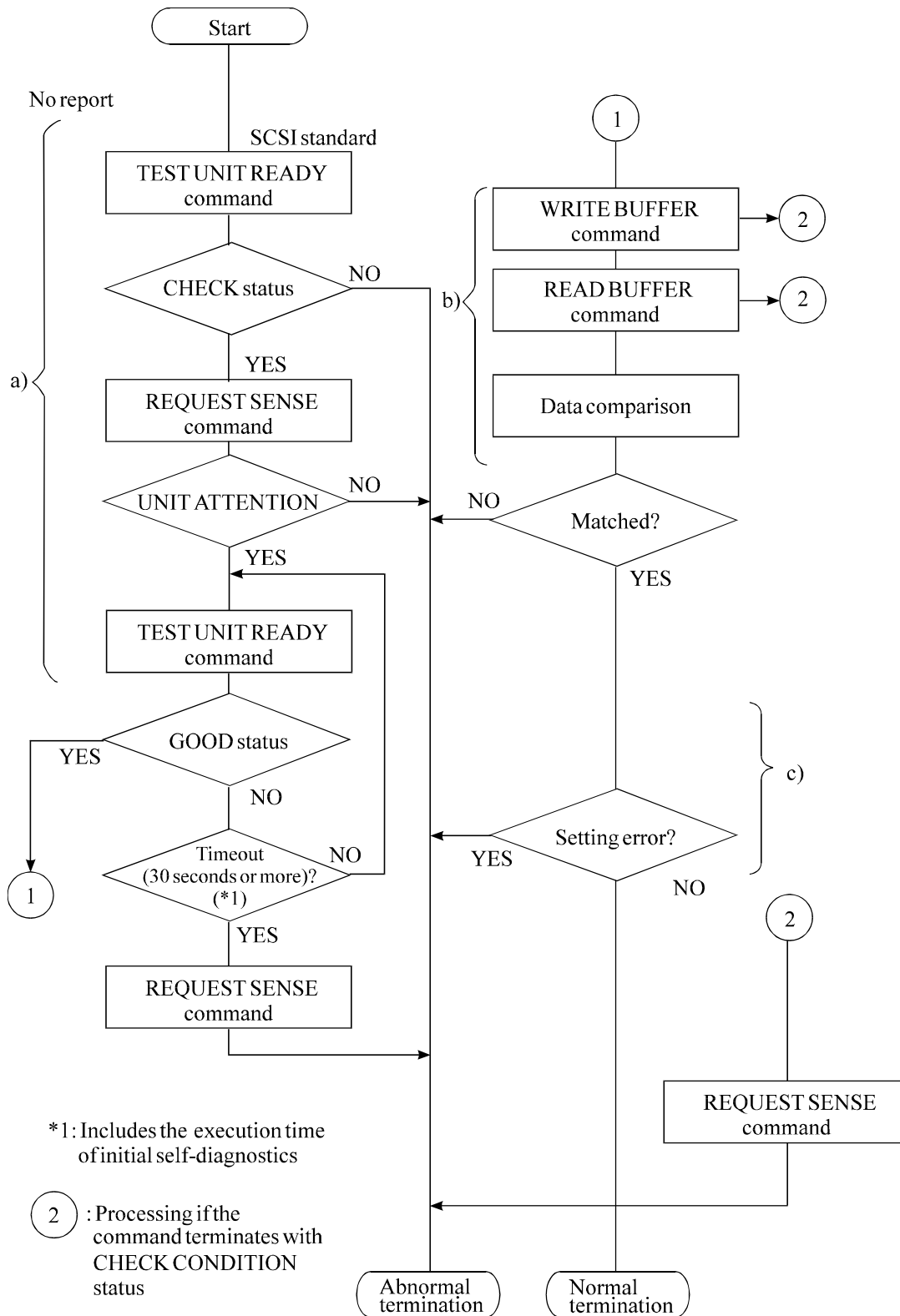

When starting the motor at power-on:

**Figure 4.6 SCSI connection check**

(2) If processing terminates abnormally:

- a) If sense data has been obtained by the REQUEST SENSE command, analyze the sense data. If the error is recoverable, retry the processing.
- b) Check the following items for SCSI cable connection:
  - All connectors, including other SCSI devices, are connected correctly.
  - A terminating resistor is correctly mounted at both ends of the cable.
  - Power is supplied to the terminating resistors correctly.
- c) Check the settings of all terminals are correct. Note that the procedure of checking the SCSI connection depends on the setting of "spindle automatic stop".

## 4.7 Dismounting Drive

How to demount an optical disk drive (for setting terminal checking, setting change, or device replacement) depends on the system cabinet configuration. Determine the demounting procedure in consideration of the requirements of each system. This section describes the general demounting procedure and notes on demounting drives.



Before demounting the optical disk drive, turn off the system power. Do not remove screws securing the cables and drive when the power is on.

- 1) Remove the power cable.
- 2) Remove the SCSI cable.
- 3) When an external operator panel is mounted, remove its cable. If it is difficult to access the connector, remove the cable after step e).
- 4) Remove the DC ground cable.
- 5) Remove the four screws securing the drive, then remove the drive from the system cabinet.
- 6) When storing or transporting the drive, put the drive into an antistatic bag. (See Section 4.1.)

This page is intentionally left blank.

# CHAPTER 5 Operation and Cleaning

5.1	Operation of Optical Disk Drive
5.2	Cleaning of Optical Disk Drive
5.3	Operation of Optical Disk Cartridge
5.4	Cleaning of Optical Disk Cartridge

This chapter describes how to operate and clean the optical disk drive and an optical disk cartridge.

## 5.1 Operation of Optical Disk Drive

The optical disk drive has automatic load and eject functions. All of the operator must do about the drive is to insert an optical disk cartridge and push the eject button. This section explains loading and ejecting an optical disk cartridge, assuming that the drive is mounted horizontally. You can operate the drive in the same manner even when it is mounted vertically.

Figure 5.1 shows the front view of the optical disk drive. The following sections explain the names and functions of parts that a user should know for operation as well as methods of loading and ejecting an optical disk cartridge.

### 5.1.1 Appearance of optical disk drive

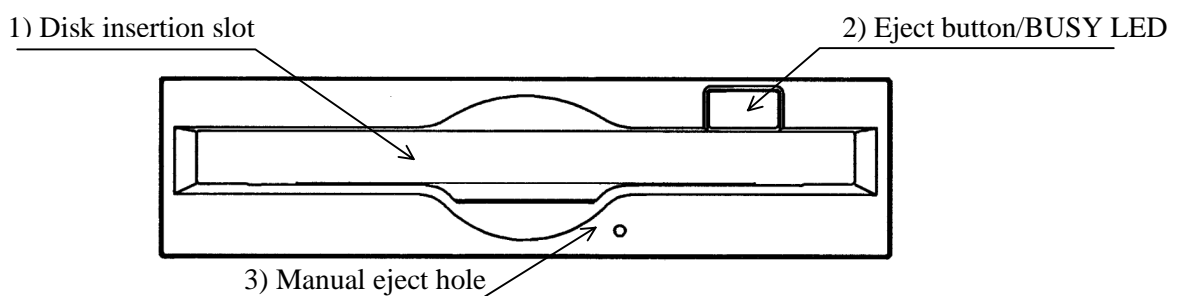

**Figure 5.1 Optical disk drive front view (with panel)**

The following explains the parts and functions of the optical disk drive (the following numbers correspond to those in Figures 5.1):

1) Disk insertion slot

Insert and eject an optical disk cartridge into and out of this slot.

2) Eject button & BUSY LED (indicator lamp)

On this optical disk drive, the eject button serves also as the BUSY LED (indicator lamp). Eject an optical disk cartridge by pressing this button, which also goes on in green during seeking and during erasing, writing or reading of data. When ejection is disabled by an SCSI command, an optical disk cartridge cannot be taken out.

3) Manual eject hole

Use this hole to eject an optical disk cartridge manually at power-off.

### 5.1.2 Precautions

To maintain the performance and reliability of the drive and to prevent data from being damaged, observe the following instructions:

- Do not eject an optical disk cartridge while the drive is in the Busy state.  
Particularly, do not manually eject the cartridge by force.
- Be extra careful not to insert the wrong media such as a floppy disk or foreign matter, which causes a malfunction of the drive.

### 5.1.3 Inserting an optical disk cartridge

Insert an optical disk cartridge as follows (see Figure 5.2):

(1) While the drive is powered on:

- 1) Make sure that there is no other optical disk cartridge in the drive.
- 2) Hold an optical disk cartridge with the printed shutter surface facing upward.
- 3) Press the opening section of the cartridge against the disk insertion slot.
- 4) Hold the center of the rear half of the cartridge to insert the cartridge straight into the slot until the cartridge is lowered to the bottom (a little inside the operator panel).

The cartridge starts to be loaded when it has been inserted. The BUSY LED indicator lamp goes on immediately and goes off in a few seconds, indicating the completion of loading.

Notes:

1. Insert a cartridge as far as it will go until the BUSY LED indicator lamp goes on.
2. A cartridge may not be sufficiently inserted if you press only the left or right edge of the rear half of the cartridge. Be sure to push the central part straight into the slot as far as it will go.

3. If the BUSY LED indicator lamp does not go on after a cartridge is inserted, press the eject/BUSY LED button once to eject the cartridge and insert it again.
4. Do not forcibly insert a cartridge if you have any difficulty inserting it. If you do, the drive may be damaged. In such a case, be sure to remove the cartridge once and check the insertion orientation and the face and back of the cartridge before inserting it again.

(2) While the drive is powered off:

- 1) Make sure that there is no other optical disk cartridge in the drive.
- 2) Hold an optical disk cartridge with the printed shutter surface facing upward.
- 3) Press the opening section of the cartridge against the disk insertion slot.
- 4) Hold the center of the rear half of the cartridge to insert the cartridge straight into the slot until the cartridge is lowered to the bottom (a little inside the operator panel).

The cartridge remains where it has been inserted. If you power on the drive, the BUSY LED indicator lamp goes on.

Notes:

1. If the BUSY LED indicator lamp does not go on when the power is turned on, press the eject button to eject the cartridge and then insert it again until the lamp goes on.
2. A cartridge may not be sufficiently inserted if you press only the left or right edge of the rear half of the cartridge. Be sure to push the central part straight into the slot as far as it will go.
3. Do not forcibly insert a cartridge if you have any difficulty inserting it. If you do, the drive may be damaged. In such a case, be sure to remove the cartridge once and check the insertion orientation and the face and back of the cartridge before inserting it again.

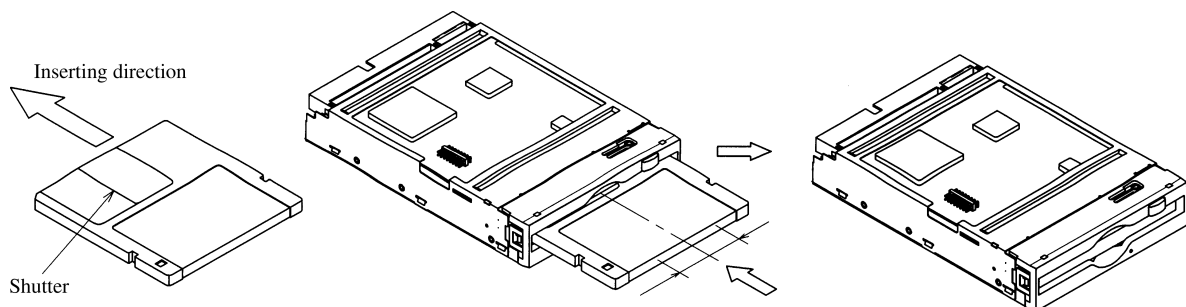

Push on the back of the cartridge somewhere within the area extending 20 mm from left of center to 20mm from right of center, up to the location shown on the right.

**Figure 5.2 Inserting an optical disk cartridge**

## IMPORTANT

If you insert an optical disk cartridge with the printed shutter facing upward by pressing on the rear of cartridge at the left edge, you may hear an audible click but the drive may not become READY. In such a case, press the cartridge further by pressing on the back of the cartridge from the center (somewhere near the notched section of the panel front) until the LED indication lamp goes on. If this happens, the cartridge has been normally inserted.

### 5.1.4 Removing an optical disk cartridge

Remove an optical disk cartridge as described below.

(1) While the drive is powered on:

- 1) Press the eject switch to remove an optical disk cartridge (see Figure 5.3).

Notes:

1. No optical disk cartridge can be removed if the SCSI command inhibits ejection.
2. Remove an optical disk cartridge after it is completely ejected.
3. Be careful not to let a cartridge drop out of the drive when it is ejected. This may happen depending on the ambient environment and the cartridge's condition even if the drive installation conditions are met.

(2) While the drive is powered off:

While the drive is powered off, you cannot remove an optical disk cartridge by pressing the eject switch.

To remove a cartridge in such a case, insert an accessory eject jig or a pin about 1 mm in diameter into the manual eject hole (see Figure 5.1) and push on it.

Notes:

1. NEVER eject a cartridge while the BUSY LED lamp is on. The data may be destroyed or the drive may be damaged.
2. Note that a cartridge may drop out of the drive when it is ejected.
3. Do not carry the optical disk drive around while a cartridge is loaded in it.



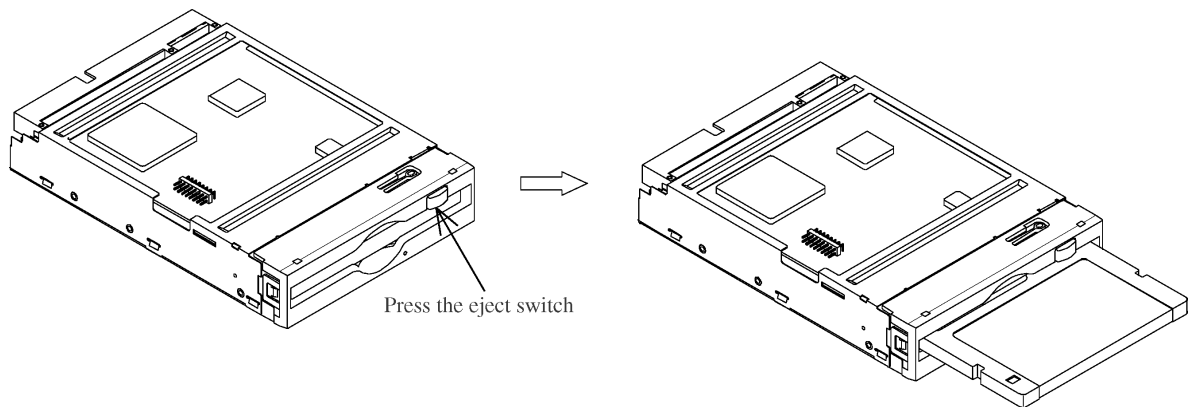

**Figure 5.3 Removing an optical disk cartridge**

## 5.2 Cleaning of Optical Disk Drive

The drive performance may deteriorate if dust, particle or cigarette smoke deposits accumulate on the lens actuator of the drive. Clean the lens actuator periodically using following head cleaner (\*1).

\*1 How often the lens actuator should be cleaned varies depending on the environment in which the optical disk drive has been installed. Usually, clean the lens actuator once every three months.

**Table 5.1 Head cleaner**

Product name	Product number	Order number
Head cleaner	0240470	CA90002-C980

Clean the lens actuator using the head cleaner as follows:

- 1) Power on the optical disk drive.
- 2) Insert the head cleaner.
- 3) When the head cleaner is automatically loaded, the optical head positioner moves back and forth to cause the head cleaner's cleaning brush to clean the object lens.
- 4) When the cleaning is finished, the head cleaner is automatically ejected.

Note: The cleaning time is around 15 seconds.



**Device Damage:**

Be sure to use the dedicated head cleaner shown above.

**IMPORTANT**

Check the state of the cleaning brush by opening the shutter of the head cleaner. If the tips of the brush bristles are spread out, the lens cannot be completely cleaned. In such a case, use a new head cleaner.

## **5.3 Operation of Optical Disk Cartridge**

### **5.3.1 Appearance**

Figure 5.4 shows the appearance of an optical disk cartridge. It also shows the names of components of an optical disk cartridge that you should be familiar with for operation and cleaning.

See Section 2.3.2, "Appearance" for the functions of these components.

(a) Shutter closed

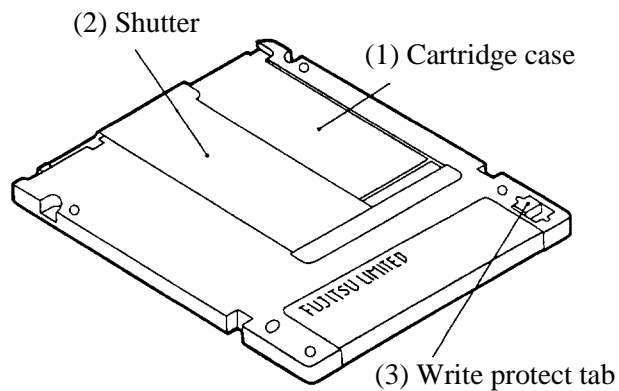

(b) Shutter open

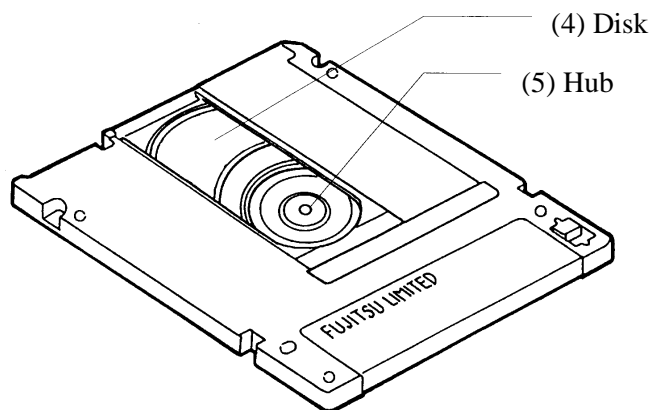
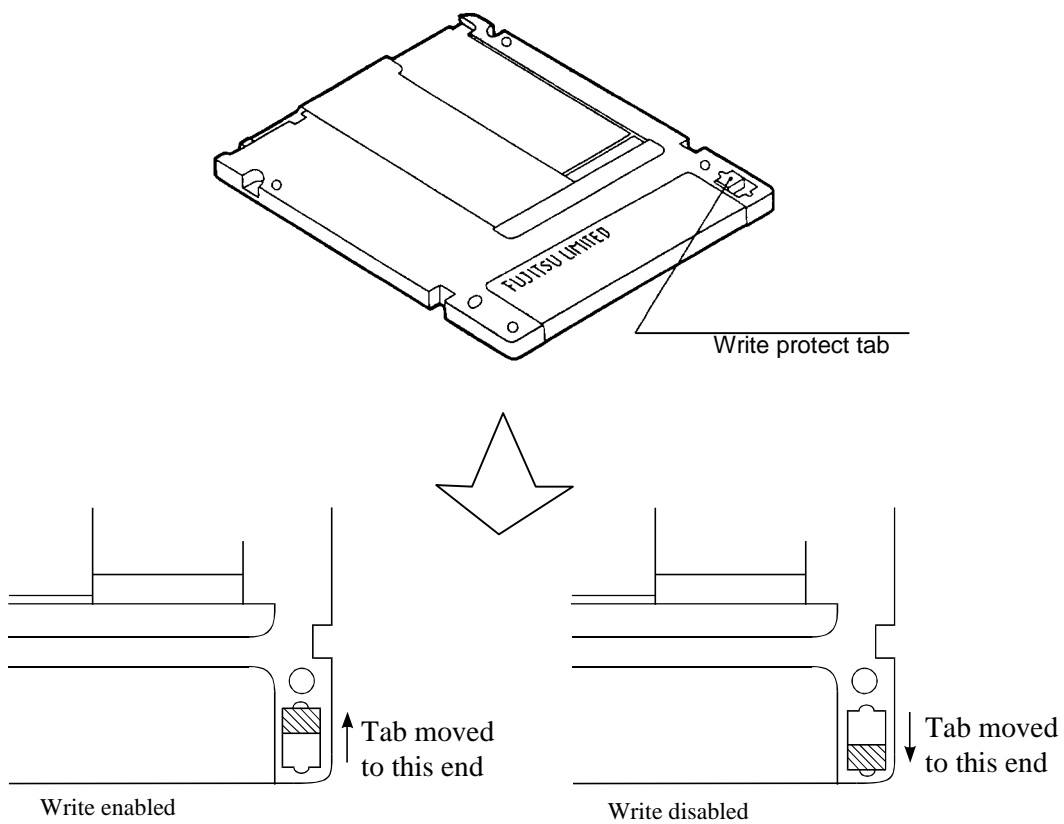

Figure 5.4 Appearance of optical disk cartridge

### 5.3.2 Write protect tab

Move the write protect tab to enable or disable writing to an optical disk cartridge. Use a fingernail or something similar to move the write protect tab (it must be completely moved to one end because there is some play in the middle).

Figure 5.5 shows where the write protect tab is located on a optical disk cartridge and how the write protect tab should be moved (see the Write Enabled and Write Disabled indications printed on the label).



Note: The write protect tab should be at each of the shaded portions.

**Figure 5.5 Write protect tab**

### 5.3.3 Precautions

To maintain the performance and reliability of an optical disk cartridge, keep the following points in mind when using, storing, or transporting an optical disk cartridge:

(1) Using a cartridge

- Do not use a cartridge in an environment where it is exposed to direct sunlight or sharp temperature changes, or high temperature or humidity.
- Do not press hard, drop, or otherwise apply excessive shock or vibration to a cartridge case or shutter.
- Do not use a cartridge in an environment filled with dust, particle, or cigarette smoke.
- Do not open the shutter or touch the surface of a disk with bare fingers.

(2) Storing a cartridge

- Do not place a heavy object on a cartridge.
- Do not store a cartridge in an environment where it is exposed to direct sunlight or sharp temperature changes, or high temperature or humidity.
- Do not store a cartridge in an environment filled with dust, particle, or cigarette smoke.

(3) Transporting a cartridge

- Transport a cartridge sealed in a nylon bag or the equivalent, to protect it from moisture during transportation.
- Put a cartridge in a solid container and cover the cartridge with appropriate cushioning materials to protect it from damage during transportation.

## 5.4 Cleaning the Optical Disk Cartridge

You must periodically clean an optical disk cartridge because the accumulation of dust, particle, or cigarette smoke deposits on the disk lowers the performance of the cartridge. How often the cartridge should be cleaned varies depending on the environment in which the optical disk drive has been installed. Usually, clean the cartridge once every 300 hours of operation or once in two to three months.

### 5.4.1 Cleaning tool for optical disk cartridge

Use the following cleaning kit to clean an optical disk cartridge.

(1) Cleaning kit

This cleaning kit is for a 3.5-inch optical disk cartridge only. Read the attached instruction manual and use the cleaning kit correctly. Table 5.2 shows the specifications of the cleaning kit.

**Table 5.2 Cleaning kit**

Product name	Product number	Order number
Cleaning kit	0632440	CA90003-0702

Table 5.3 shows the packing list of the cleaning kit.

**Table 5.3 Packing list for cleaning kit**

Name	Quantity
Setting case	1
Cleaning cloth	5 pieces (70mm × 70mm)
Cleaning solution	1 bottle (20ml)

The following refill kit is available for the cleaning solution and cloth.

- Product number 0632450
- Order number CA90002-D901



**Disk damage:** To clean a disk, use the cleaning solution and cleaning cloth specified in Table 5.2.

If a cleaning solution or cleaning cloth other than the one specified is used, the surface of a disk may be damaged.

(2) Precautions on use and storage of cleaning kit

Keep the following in mind when using or storing the cleaning kit:

- Tighten the cap after using the cleaning solution.
- Do not insert a floppy disk or stack floppy disks in the setting case because a magnet is used at the disk revolving knob of the setting case.
- Do not use or store the cleaning kit in an environment where it is exposed to direct sunlight or near a flame.
- Keep the cleaning kit out of the reach of children.

**CAUTION**

**Disk damage:** Do not use this cleaning kit on a floppy disk or an optical disk cartridge to be used on other optical disk drives.

### 5.4.2 Cleaning of optical disk cartridge

Clean an optical disk cartridge as follows:

**CAUTION**

**Disk damage:** Clean a cartridge in a dust-free environment. Fujitsu recommends wearing disposable gloves during cleaning so that no fingerprints are left on a disk.

- 1) Slide the cartridge shutter until it is completely open (see Figure 5.6).

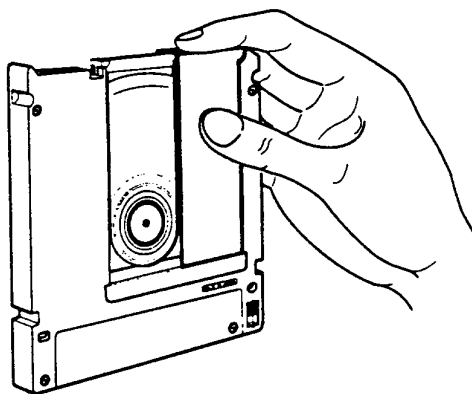

**Figure 5.6 Opening a shutter**

- 2) Set the cartridge with the printed shutter surface facing downward and with the shutter completely open, into the shutter stopper of the setting case as shown in Figure 5.7.

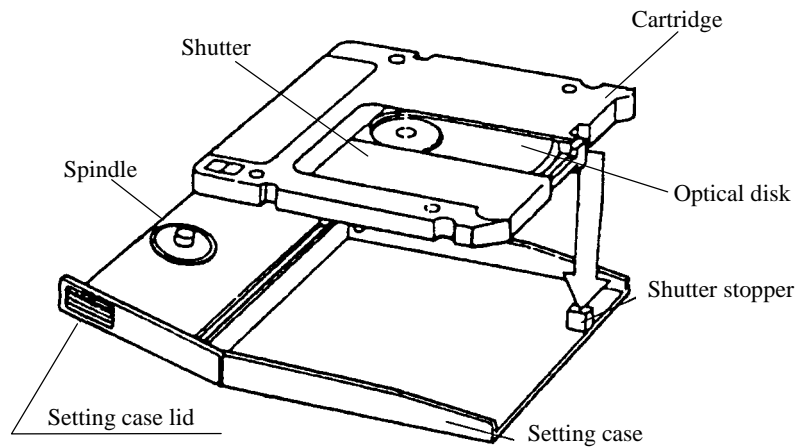
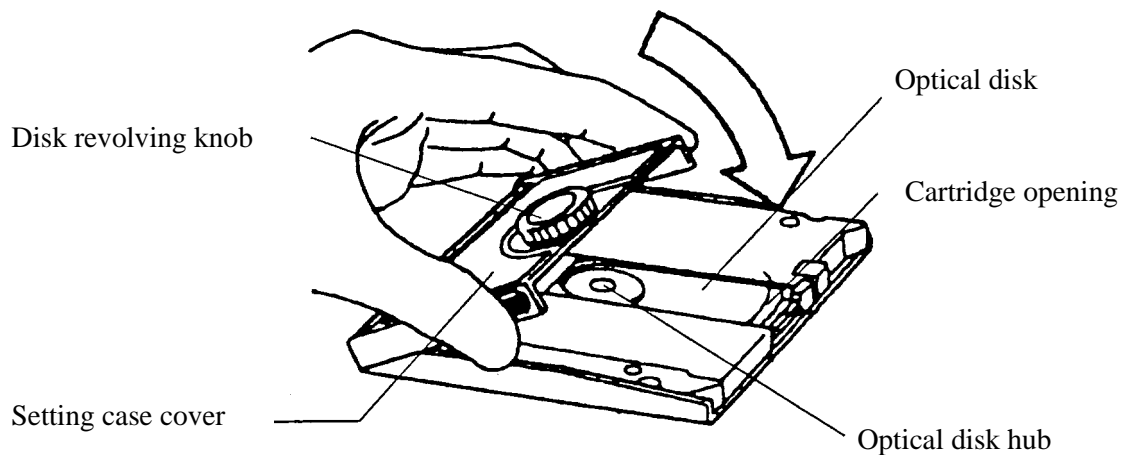

**Figure 5.7 Setting an optical disk cartridge into the setting case**

**CAUTION**

**Disk damage:** Do not press hard or apply excessive shock to an optical disk cartridge case while setting it in the setting case.

- 3) Place the setting case cover over the cartridge while inserting the disk revolving knob pin into the center hub of the cartridge (see Figure 5.8).



**Figure 5.8 Placing the setting case cover**

- 4) When wiping the disk, remove from the disk surface any fragments that may damage it.
- 5) Moisten the accessory cleaning cloth with a few drops of the cleaning solution.



**CAUTION**

**Eye inflammation:** If the cleaning solution gets into your eyes, immediately wash the solution away with water.

- 6) Gently wipe the disk surface, going from the center to the edge of the disk.
- 7) After wiping, turn the disk-revolving knob and then wipe the next section in the same manner (see Figure 5.9).

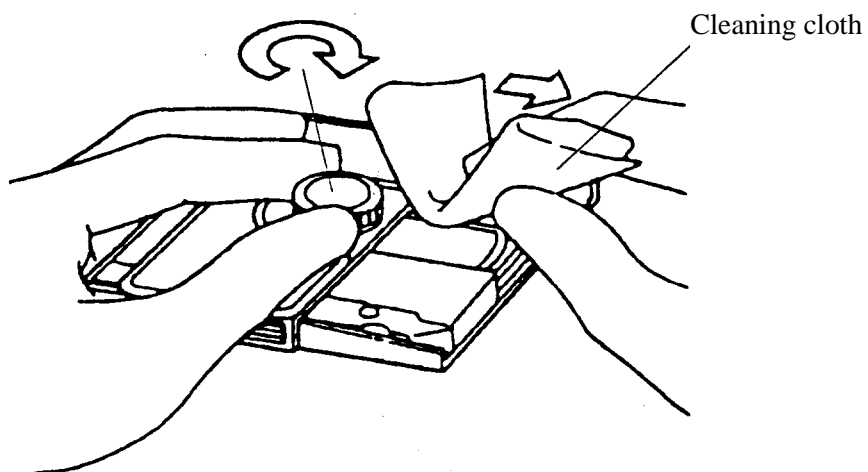

**Figure 5.9 Cleaning of disk surface**

- 8) Wipe off any excess cleaning solution remaining on the disk surface, using a new portion of the cleaning cloth (where no cleaning solution is absorbed).

This page is intentionally left blank.

# CHAPTER 6 Diagnostics and Maintenance

6.1	Diagnostics
6.2	Maintenance Information

This chapter provides diagnostics and maintenance information.

## 6.1 Diagnostics

Table 6.1 lists test items during diagnostics.

The optical disk drive has a self-diagnostics function. This function can check the normality of basic operations of the drive.

To check the generation operations including the operations of the interface with the host system, provide a test program that can run in the host system (see Section 6.1.3).

**Table 6.1 Diagnostics function**

Description of diagnostics	Diagnostics item
Initial self-diagnostics	Basic operations (hardware function test)
Diagnostic command	Basic operations
Test program	General operations

### 6.1.1 Initial self-diagnostics

When the power is turned on, the optical disk drive executes initial self-diagnostics. The initial self-diagnostics tests basic hardware operations.

The hardware function test checks the normality of the basic operations of the controller. This test includes the normality check of the ROM that stores microcodes, microprocessor (MPU) peripheral circuit test, memory (RAM) test, and data buffer test.

The LED on the drive front panel blinks if an error is detected during initial self-diagnostics.

## **6.1.2 Diagnostic command**

The host system issues the EXECUTIVE DEVICE DIAGNOSTIC command to cause the ODD to execute self-diagnostics.

See the description on the EXECUTIVE DEVICE DIAGNOSTIC command for more information.

## **6.1.3 Test program**

To check the operations of the interface with the host system and the general operations in an environment that simulates an actual operation status, provide a test program that can run in the host system.

The configuration and function of the test program depend on the requirements of the user system.

To comprehensively test the functions of the optical disk drive, the Fujitsu recommends that the test program include the following test items:

### (1) Random/sequential read test

Use the READ or VERIFY command to test the positioning (seek) and read operations in both random access mode and sequential access mode.

### (2) Write/read test

Using a disk whose data may be erased, execute write/read test based on arbitrary data patterns.

## **6.2 Maintenance Information**

### **6.2.1 Maintenance requirements**

#### (1) Preventive maintenance

No preventive maintenance is required.

#### (2) Service life

This drive will not require overhaul within the first five years of installation if it is used in an appropriate environment and handled as recommended.

#### (3) Service system and repair

Fujitsu provides a service system and repair facility for its optical disk drives. Submit to your Fujitsu representative information required to replace or repair a drive. Normally, the information includes:

- a) Optical disk drive model, product number (P/N), revision number, serial number (S/N), and date of manufacture

- b) Failure status
  - Date of failure
  - System configuration
  - Environment conditions (temperature, humidity, supply voltage, etc.)
- c) Failure history
- d) Failure description
  - Description of failure
  - Issued commands and specified parameters
  - Sense data
  - Other error analysis information

### ▲ CAUTION

**Data loss:** For a repair request, you normally do not need to include any optical disk cartridge with an optical disk drive. However, you do need to include a cartridge if errors keep occurring with a specific cartridge. In such a case, be sure to save data stored in the cartridge before sending it in. Fujitsu shall bear no responsibility for any data lost during service or repair.

See Section 5.3.3, "Precautions" for information on packing and handling a drive when you send it to Fujitsu.

## 6.2.2 Revision number

The revision number of an optical disk drive is represented with an alphabetic character followed by a single-digit number. The revision number is shown on a revision label attached to the drive. For example, Figure 6.1 shows the format of a revision label.

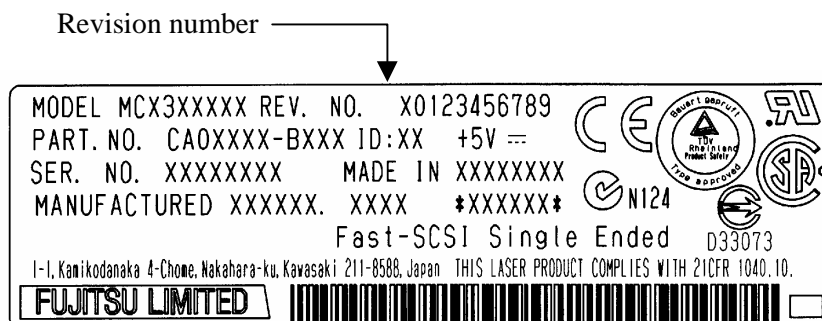

**Figure 6.1 Revision label**

(1) Indication of revision number at shipment

The revision number indicated on the drive at the time of shipment is indicated by marking (crossing out) the numbers up to the pertinent number using double lines (=) in the line of the pertinent alphabetic character (see Figure 6.2).

(2) Change of revision number in the field

To change the revision number in the field because of parts replacement or modification, indicate the new revision number by circling the number in the line of the pertinent alphabetic character (see Figure 6.2).

If a revision number is changed after shipment, Fujitsu issues "Revision Number Change Request/Notice" to indicate the new revision number. The user must update the revision label as described above after applying the change.

Indication of revision number at shipment

REV.NO. A ~~0~~ ~~1~~ ~~2~~ 3 4 5 6 7 8 9      Revision A2

Change of revision number in field

REV.NO. A ~~0~~ 1 2 ③ 4 5 6 7 8 9      Revision A3

Note: "A" in Revision Number is impressed.

**Figure 6.2 Revision number indication**

# CHAPTER 7 SCSI BUS

7.1	System Configuration
7.2	Interface Signal Definition
7.3	Physical Requirements
7.4	Electrical Requirements
7.5	Timing Rule
7.6	Bus Phases
7.7	Bus Conditions
7.8	Bus Sequence

This chapter describes the structure of the SCSI bus, electrical conditions, interface protocol and their operations.

## IMPORTANT

The ODD operates on the SCSI bus as a TARG. In this chapter, the ODD is represented as "TARG" except where some special distinction must be made.

## 7.1 System Configuration

Up to eight SCSI devices can be connected to the SCSI bus. Figure 7.1 shows a sample system configurations of a multi-host system. Number of devices to be connected is restricted according to the synchronized transfer speed. Refer to the related specifications for detail. Communication on the SCSI bus is allowed between only two SCSI devices, an initiator (INIT) and a target (TARG), at any given time.

In the configured system, any combination is allowed for an SCSI device to work as an INIT and as a TARG. Also, there may be an SCSI device that works as both an INIT and a TARG.

A unique address (SCSI ID) is assigned to each SCSI device. The SCSI ID corresponds to one bit of the SCSI data bus. The INIT designates an I/O device connected to the TARG by its logical unit number (LUN).

The SCSI ID of the ODD can be selectable among #0 to #7, but the LUN is fixed to #0.

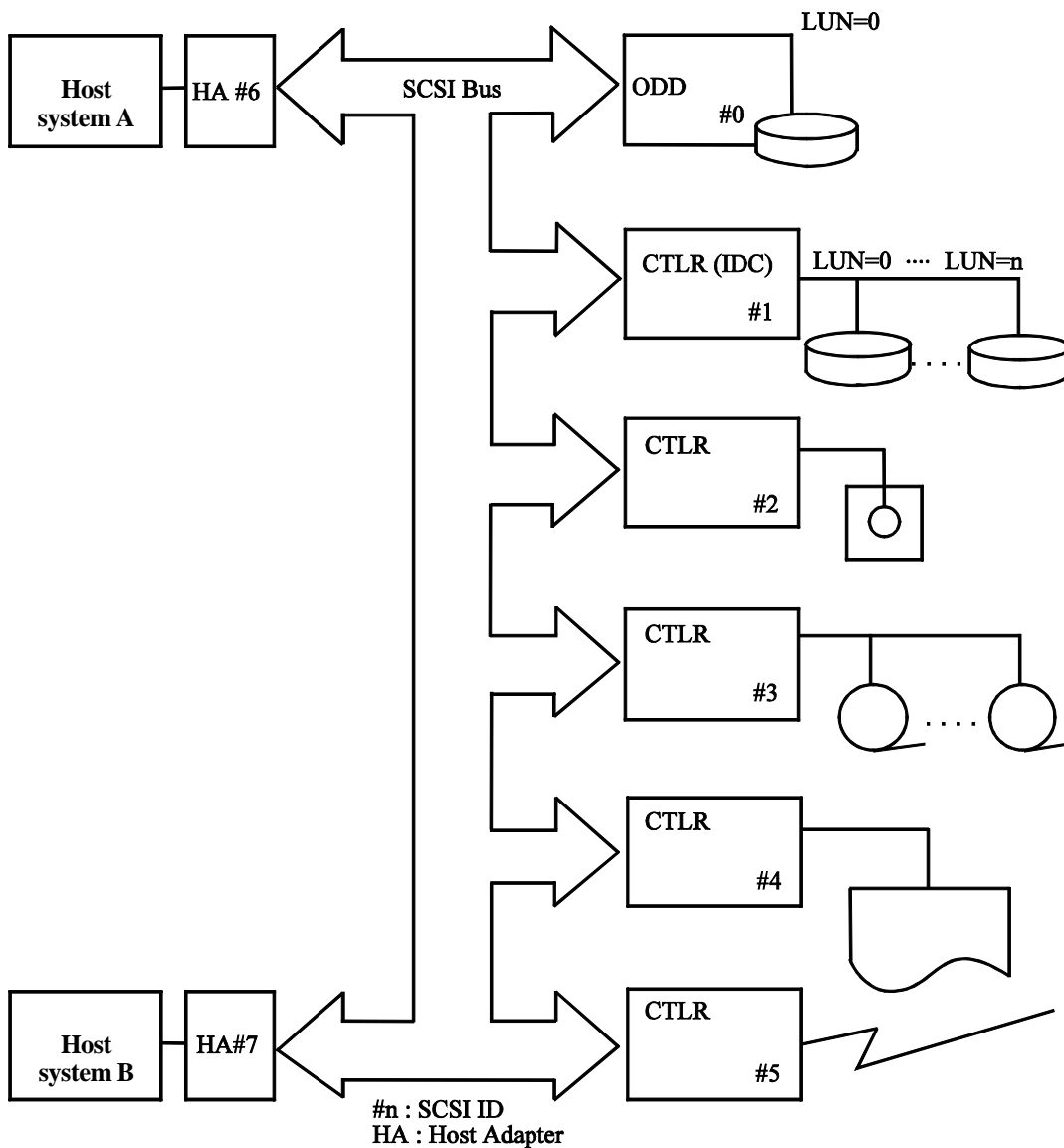

**Figure 7.1 Example of SCSI configuration**

A unique device address (SCSI ID: #n in Figure 7.1) is assigned to each SCSI device. Input-output devices connected to or under an SCSI device operating as a target are accessed in logical units. A unique device address (LUN: logical unit number) is assigned to each logical unit.

An initiator specifies an SCSI ID to select an SCSI device operating as a target, then specifies an LUN to select the input-output device connected to or under the target.

An optical disk drive is constructed with all volumes as a single logical unit. Specificable SCSI IDs and LUN are as follows:

- SCSI ID: #0 to #7 selectable (setting terminal or external input)
- LUN: #0 (fixed)



## 7.2 Interface Signal Definition

There is a total of eighteen signals. Nine are used for control and nine are used for data (1 byte data + 1 odd parity bit). Figure 7.2 shows interface signal lines.

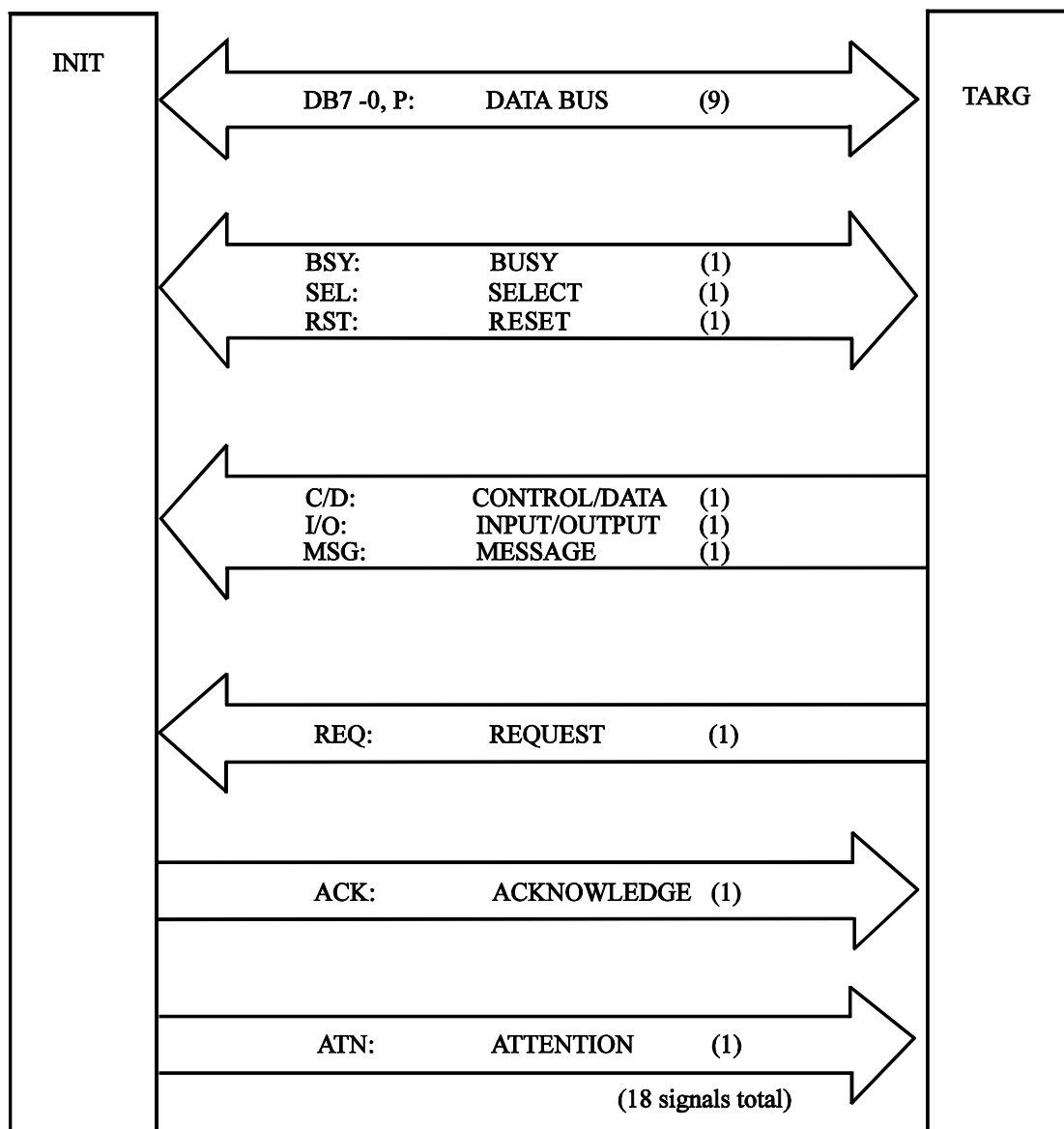

Figure 7.2 Interface signals

(1) DB 7 to 0, P (DATA BUS)

These signals form a bidirectional data bus consisting eight data bits and an odd parity bit.

MSB (27): DB7, LSB (20): DB0

The DATA BUS is used to transfer commands, data, status, or messages in the INFORMATION TRANSFER phase. SCSI IDs are sent to the DATA BUS in the ARBITRATION phase for determining the priority of bus arbitration. In the SELECTION or RESELECTION phase, SCSI IDs of the INIT and the TARG are indicated on the DATA BUS. Figure 7.3 shows the correspondence between DATA BUS bits and SCSI IDs.

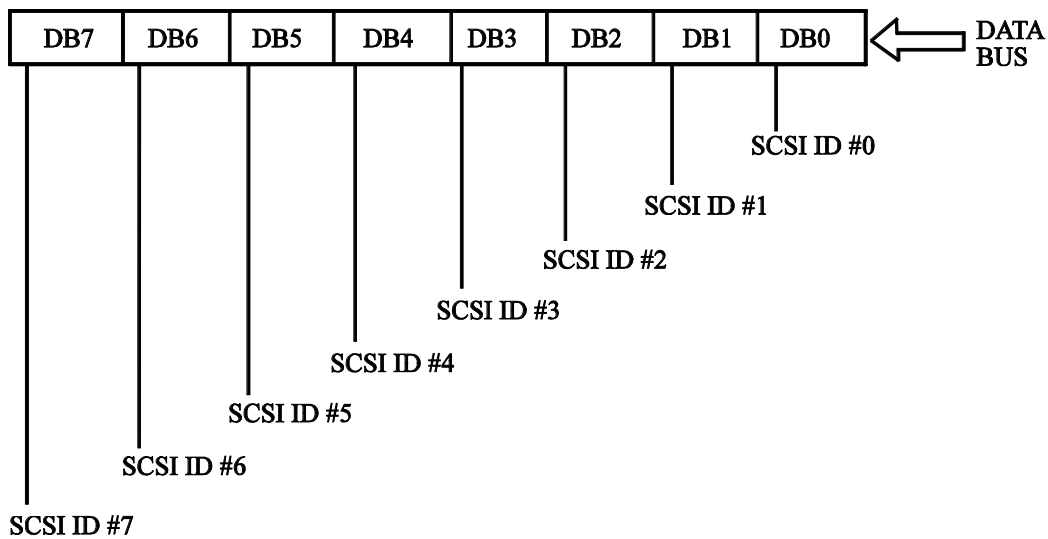

**Figure 7.3 DATA BUS and SCSI ID**

When the DB(n) signal is true, the data bit (n) is 1, and when false, it is 0.

The use of a parity bit is a system option. The ODD handles parity as shown below:

- The ODD implements the bus parity check feature, which can be enabled or disabled by a setting terminal on the ODD. For the setting terminal, refer to Item (2) in Subsection 4.3.1 in OEM Manual -Specifications & Installation-.
- Parity values are always guaranteed when valid data is transferred to the data bus from the ODD in a phase other than the ARBITRATION phase.

(2) BSY (BUSY)

This signal indicates that the SCSI bus is being used. In the ARBITRATION phase, it indicates an arbitration request.

## (3) SEL (SELECT)

This signal is used by an INIT to select a TARG (SELECTION phase) or by a TARG to reselect an INIT (RESELECTION phase).

## (4) C/D (CONTROL/DATA)

This signal is driven by a TARG to identify the type of information transferred on the DATA BUS in combination of I/O and MSG signals. (See Table 7.1)

## (5) I/O (INPUT/OUTPUT)

This signal is driven by a TARG to specify the information transfer direction on the DATA BUS or to identify a SELECTION or RESELECTION phase. (See Table 7.1)

## (6) MSG (MESSAGE)

This signal is driven by a TARG to indicate that a message is being transferred on the DATA BUS. (See Table 7.1)

## (7) REQ (REQUEST)

This signal is driven by a TARG to indicate a transfer request to an INIT in INFORMATION TRANSFER phase.

## (8) ACK (ACKNOWLEDGE)

This signal is driven by an INIT to indicate a response for REQ signal to a TARG in the INFORMATION TRANSFER phase.

## (9) ATN (ATTENTION)

This signal is driven by an INIT to indicate that the INIT has a message to be transferred to the TARG and is used to generate an ATTENTION condition.

## (10) RST (RESET)

This signal indicates the RESET condition which is used to clear all SCSI devices on the bus.

**Table 7.1 INFORMATION TRANSFER phase identification**

C/D	I/O	MSG	DB7-0, P	Direction	Phase
0	0	0	Data	INIT → TARG	DATA OUT
0	1	0	Data	INIT ← TARG	DATA IN
1	0	0	Command (CDB)	INIT → TARG	COMMAND
1	1	0	Status	INIT ← TARG	STATUS
0	0	1	–	–	not used
0	1	1	–	–	not used
1	0	1	Message	INIT → TARG	MESSAGE OUT
1	1	1	Message	INIT ← TARG	MESSAGE IN

### 7.3 Physical Requirements

SCSI devices are daisy-chained together. Both ends of the interface cable are terminated with resistors.

#### 7.3.1 Interface connector

The nonshielded SCSI connector installed on the ODD is a 50-conductor connector consisting of two rows of 25 male pins with adjacent pins 2.54 mm (0.1 in.) apart. See Figure 7.4.

The nonshielded cable connector shall be a 50-conductor connector consisting of two rows of 25 female contacts with adjacent contacts 2.54 mm (0.1 in.) apart. The use of keyed connectors is recommended to prevent accidental misinsertion. See Figure 7.5.

Figure 7.6 shows the nonshielded connector pin assignments for SCSI.

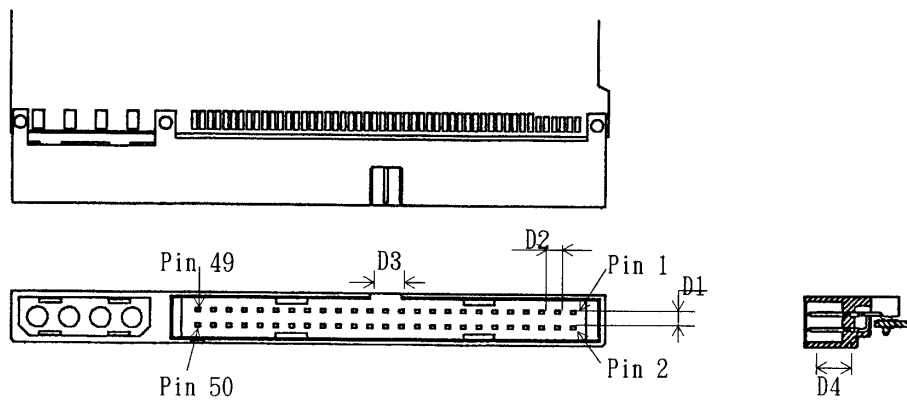

Symbol	mm	Remark
D1	2.54	_____
D2	2.54	_____
D3	5.08	_____
D4	6.25	_____

Note: The tolerance is  $\pm 0.127$  mm unless otherwise specified.

**Figure 7.4 SCSI interface connector (ODD side)**

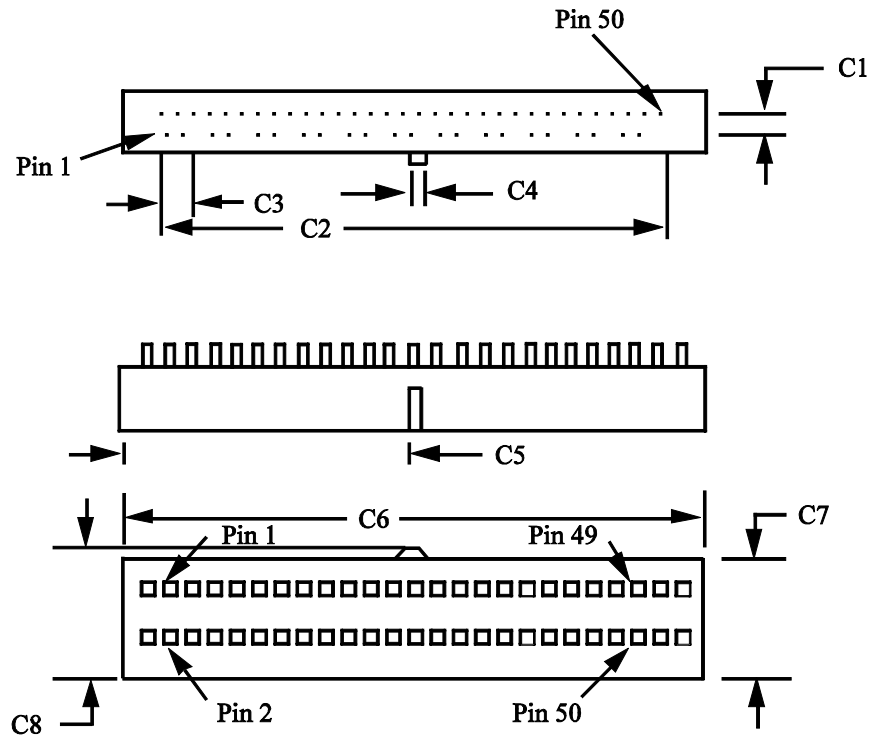

Symbol	mm	Remarks
C1	2.540	_____
C2	60.960	_____
C3	2.540	_____
C4	3.302	_____
C5	32.385	_____
C6	68.072	_____
C7	6.096	_____
C8	7.620	Maximum value

Notes: 1. The tolerance is  $\pm 0.127$  mm unless otherwise specified.  
 2. A connector cover and strain relief are not shown in this figure.

**Figure 7.5 SCSI interface connector (cable side)**

01	G	-DB0	02
03	G	-DB1	04
05	G	-DB2	06
07	G	-DB3	08
09	G	-DB4	10
11	G	-DB5	12
13	G	-DB6	14
15	G	-DB7	16
17	G	-DBP	18
19	G	G	20
21	G	G	22
23	G	G	24
25	Open	TERMPWR*	26
27	G	G	28
29	G	G	30
31	G	-ATN	32
33	G	G	34
35	G	-BSY	36
37	G	-ACK	38
39	G	-RST	40
41	G	-MSG	42
43	G	-SEL	44
45	G	-C/D	46
47	G	-REQ	48
49	G	-I/O	50

\* Terminating resistor power supply (jumper selectable: input only, both input and output, or open)

**Figure 7.6 SCSI interface connector pin assignments (single-ended type)**

### **IMPORTANT**

Note that shielded end processing is not performed with the connector on the main unit's optical disk unit for cables that use pin No.9 as the shielded ground.

### 7.3.2 Interface cable

For the interface cable, a 25-pair, twisted-pair cable that satisfies the requirements listed in Table 7.2 should be used.

**Table 7.2 Interface cable requirements**

Item	
Conductor size	28 AWG or bigger
Characteristic impedance	100Ω to 132Ω

In the 25-pair twisted cable, pins  $n$  and  $n + 1$  (where  $n$  is odd) on the interface connector must be connected to a pair. Cables having the same characteristic impedance must be used in the same SCSI bus to reduce signal reflection and maintain transmission characteristics.

The maximum length of the interface cable is 6 m. But the cable length is restricted according to the synchronized transfer speed. When an SCSI device is connected to the interface cable except at one of the ends, the connection to the SCSI connector must be at a cable branchpoint. When an SCSI device is connected to an end of the SCSI bus, there must not be any cable wiring after the SCSI device unless the cable has a terminating resistor. (See Figure 7.7.)

(a) Connection to a middle point of the cable

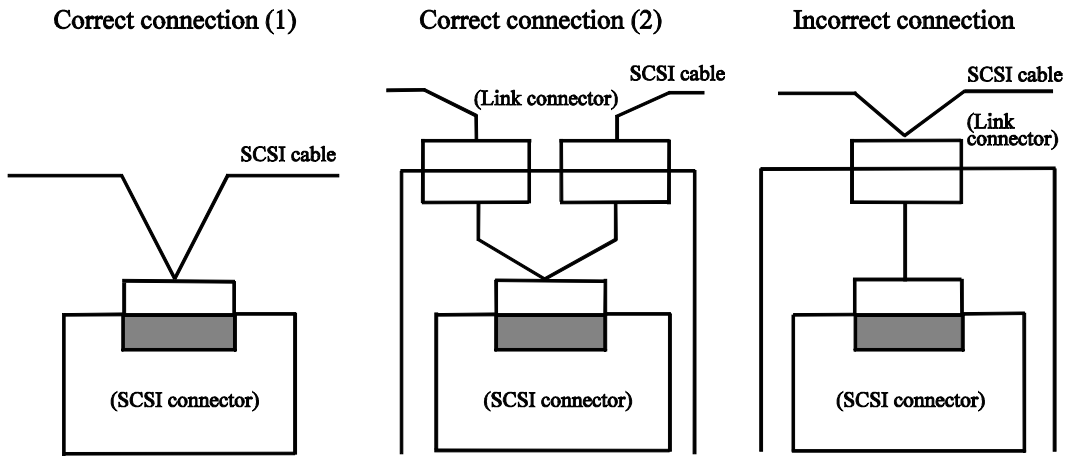

(b) Connection to the end of the cable

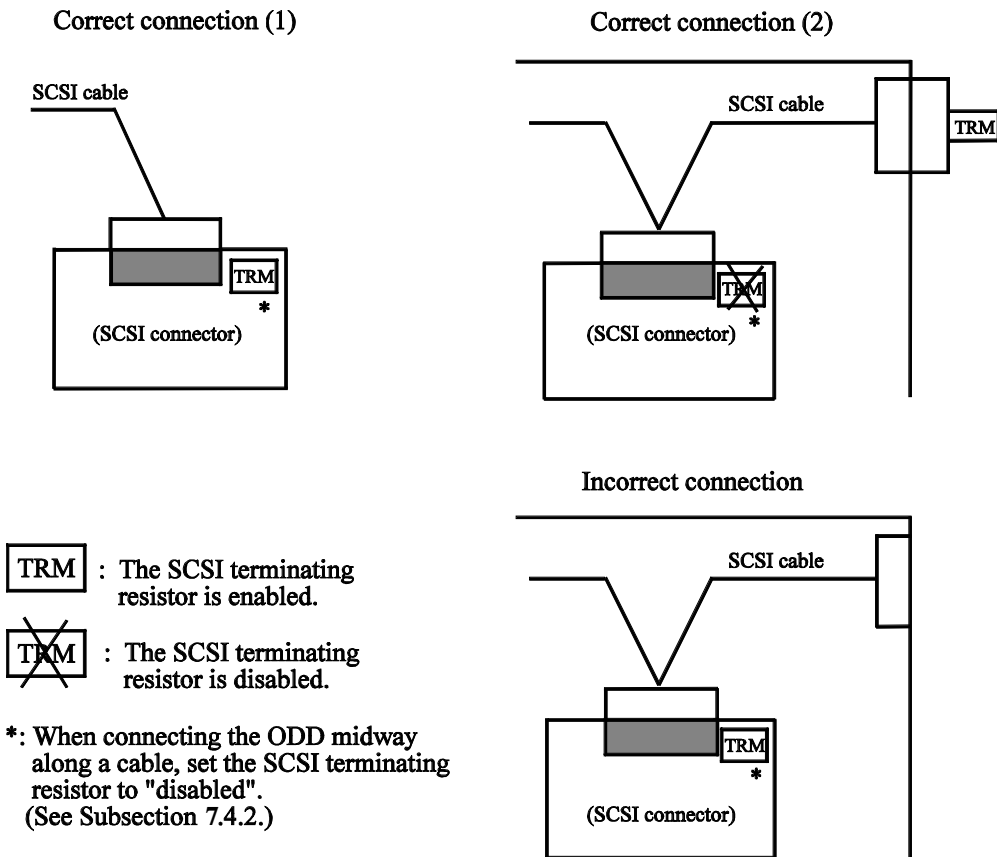

Figure 7.7 Connection of interface cable



## 7.4 Electrical Requirements

### 7.4.1 SCSI interface

#### (1) Driver and receiver

For the interface signal driver, an open-collector or tri-state buffer circuit that satisfies the following output characteristics is used. All signals are negative logic (true = "L").

The receiver and non-driver of the SCSI device under the power-on state should satisfy the following input characteristics on each signal.

#### Output characteristics

$$V_{OL} = 0.0 \text{ to } 0.50 \text{ VDC (@ } I_{OL} = 48 \text{ mA)}$$

$$V_{OH} = 2.5 \text{ to } 5.25 \text{ VDC}$$

#### Input characteristics

$$V_{IL} = 0.0 \text{ to } 0.80 \text{ VDC}$$

$$I_{IL} = -0.4 \text{ to } 0.0 \text{ mA (@ } V_I = 0.5 \text{ VDC)}$$

$$V_{IH} = 2.0 \text{ to } 5.25 \text{ VDC}$$

$$I_{IH} = 0.0 \text{ to } 0.1 \text{ mA (@ } V_I = 2.7 \text{ VDC)}$$

Input hysteresis = 0.2 VDC min.

Input capacitance = 25 pF max.

Note: The SCSI device under the power-off state should satisfy the characteristics of  $I_{IL}$  and  $I_{IH}$ .

#### Recommended circuit

Driver: MB463 (Fujitsu) or SN7438 (TI) (Open-collector NAND gate)

Receiver: SN74LS240 or SN74LS19 (TI) (Schmitt trigger input inverter)

(2) Termination circuit

The termination circuit is a resistor termination as shown in Figure 7.8. The termination circuits are installed in SCSI devices which are connected at both ends of the interface cable.

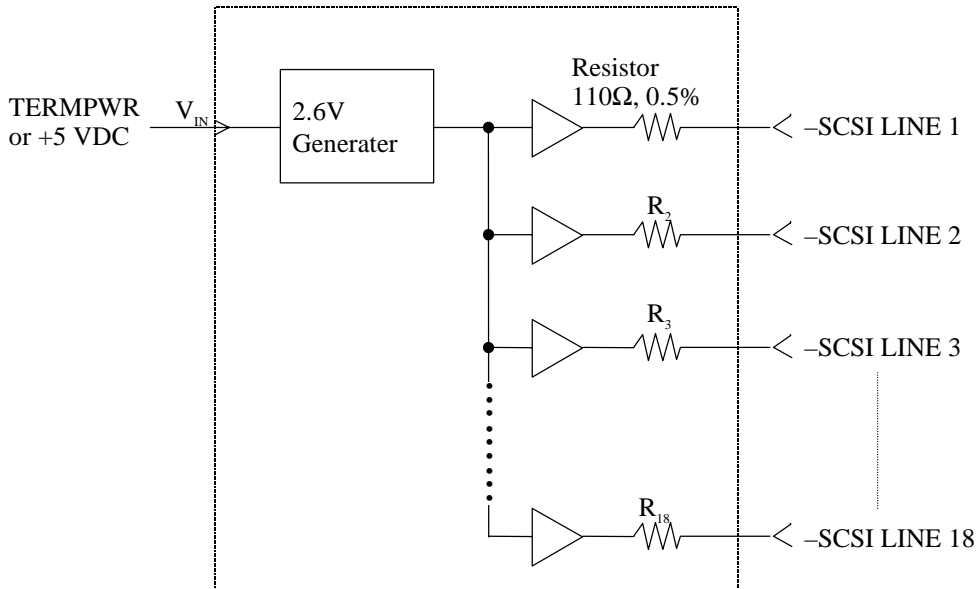

Figure 7.8 SCSI termination circuit

7.4.2 Power supply for terminating resistor

The TERMPWR signal on the interface connector is used to supply power to the terminating resistor circuit connected to both ends of the cable. In a system configuration where the terminating resistor is installed outside the SCSI device or if there is a possibility of the power to the SCSI device with the terminating resistor being cut off, power for the terminating resistor must be supplied to the TERMPWR line from an SCSI device on the bus. The SCSI device always working as an INIT (example: host adapter) should supply that power. Power must be supplied to the TERMPWR line through a diode or other element to prevent reverse current.

Table 7.3 lists the requirements for terminating the resistor power supply ( $V_{term}$ )

Table 7.3 Requirements for terminating resistor power supply

Item	Single-ended type
Output voltage	4.25 to 5.25 VDC
Current capacity	900 mA min.
Sink current	1.0 mA max.

### 7.4.3 Signal driving conditions

#### (1) Signal status value

Table 7.4 shows the correspondence between the input interface signal level at the receiving end and its logic state.

**Table 7.4 Signal status**

Logic state	Signal level (at receiving end)
	Single-ended type
True, "1", or asserted	Low (0.0 to 0.8 VDC)
False, "0", negated,, or released	High (2.0 to 5.25 VDC)

#### (2) Signal driving method

Two driving methods are available: "OR-tied" type and "non-OR-tied" type as indicated in Table 7.5.

**Table 7.5 Signal driving method**

Signal status	Driving method	
	"OR-tied" type	"Non-OR-tied" type
False (*1)	No SCSI device drives a signal. The signal becomes false when the terminating resistor circuit is biased.	A particular SCSI device drives the signal false. Otherwise, no SCSI device drives the signal.
True	An SCSI device drives the signal true.	

\*1 In this manual, the signal is said to be false if one of the following conditions is satisfied.

- The signal is actually driven by an SCSI device to become false (non-OR-tied type).
- No SCSI device is driving the signal (OR-tied type or non-OR-tied type).

In the interface operating sequence, the driving method of the BSY and RST signals which may be driven by two or more SCSI devices simultaneously must be the "OR-tied" type. Signals other than BSY, RST, or DBP are not driven by more than one SCSI device. Signals other than BSY or RST can be driven by either the "OR-tied" type or "non-OR-tied" type. The DBP signal must not be driven false in the ARBITRATION phase. For signals other than BSY or RST, both "OR-tied" and "non-OR-tied" types can be mixed on the SCSI bus.

## (3) Signal sources

Table 7.6 lists signal sources for each interface phase.

**Table 7.6 Bus phases and signal sources**

Signal Bus phase	BSY	SEL	I/O	C/D MSG	REQ	ACK	DB7-0, P	ATN	TRS
BUS FREE	N	N	N	N	N	N	N	N	A
ARBIRATION	A	W	N	N	N	N	ID	N	A
SELECTION	I&T	I	N	N	N	N	I	I	A
RESELECTION	I&T	T	T	N	N	N	T	I	A
COMMAND	T	N	T	T	T	I	I	I	A
DATA IN	T	N	T	T	T	I	T	I	A
DATA OUT	T	N	T	T	T	I	I	I	A
STATUS	T	N	T	T	T	I	T	I	A
MESSAGE IN	T	N	T	T	T	I	T	I	A
MESSAGE OUT	T	N	T	T	T	I	I	I	A

A: Any SCSI device can drive the signal. Two or more SCSI devices may drive the signal at the same time.

I: Only the SCSI device which operates as an INIT can drive the signal.

I&T: INIT, TARG, or both can drive this signal according to the interface sequence.

In the RESELECTION phase, there is a sequence to be driven simultaneously by both.

ID: Each SCSI device which is actively arbitrating the bus drives a unique data bit (SCSI ID). The parity bit may be undriven or driven to the true state, but must never be driven to the false state.

N: Not to be driven by any SCSI device. The terminator pulls the signal to the false state.

T: Only the SCSI device which operates as an TARG can drive the signal.

W: Only one SCSI device which wins ARBITRATION can drive the signal.

## 7.5 Timing Rule

Table 7.7 gives the timing required for operations on the SCSI bus.

Table 7.7 lists SCSI FAST-20 timing specifications for operations on the SCSI bus. Table 7.8 lists asynchronous, SCSI-1, and FAST-SCSI timing specifications.

**Table 7.7 Timing specifications (1 of 3)**

No.	Name	Standard	Timing specification
1	Arbitration Delay	2.4 $\mu$ s min.	The minimum wait period between the time the SCSI device sends a BSY signal and the time the value on the data bus for determining the priority of bus use is judged in the ARBITRATION phase. A maximum time is not defined.
2	Assertion Period	15 ns min.	Minimum pulse width of an ACK signal sent by INIT and an REQ signal sent by TARG for synchronous data transfer.
3	Bus Clear Delay	800 ns max.	<p>Maximum allowable period between the time either of the following events occurs and the time the SCSI device stops driving all bus signals.</p> <p>(1) Detection of the BUS FREE phase (when both BSY and SEL signal become false during Bus Settle Delay).</p> <p><b>Note:</b></p> <p>Maximum allowable period between the time both BSY and SEL signal became false and the time the bus is released is 1,200 ns.</p> <p>An SCSI device that requires a period longer than Bus Settle Delay for the detection of the BUS FREE phase must release the bus within (Bus Clear Delay) minus (Bus Settle Delay excess time).</p> <p>(2) Another SCSI device asserts the SEL signal during an ARBITRATION phase.</p> <p>(3) The RST signal becomes true (RESET condition).</p>
4	Bus Free Delay	800 ns min.	Minimum wait period between the time the SCSI device detects a BUS FREE phase and the time it sends a BSY signal to initiate an ARBITRATION phase.
5	Bus Set Delay	1.8 $\mu$ s max.	Maximum allowable period between the time an SCSI device detects a BUS FREE phase and the time it sends BSY and SCSI ID signals to initiate an ARBITRATION phase.

**Table 7.7 Timing specifications (2 of 3)**

No.	Name	Standard	Timing specification
6	Bus Settle Delay	400 ns min.	Minimum wait period between the time a particular control signal condition changes and the time the bus condition is stabilized.
7	Cable Skew Delay	3 ns max.	Maximum allowable difference in transmission time over the interface cable between any two bus signals from any two SCSI devices.
8	Data release Delay	400 ns max.	Maximum allowable period between the time an I/O signal changes its status from false to true and the time the INIT stops driving data bus signals.
9	Deskew Delay	15 ns min.	Time for compensation for skew involved in bus signal transmission.
10	Hold Time	16.5 ns min.	In synchronous data transfer mode, the minimum time during which the transfer data on the DATA BUS from the leading edge of the REQ or ACK signal pulse must be maintained to compensate for the hold time in the SCSI device receiving data.
11	Negation Period	15 ns min.	In synchronous data transfer mode, the minimum time from the trailing edge of an REQ signal to the leading edge of the next REQ signal, or from the trailing edge of an ACK signal to the leading edge of the next ACK signal.
12	Power-On to Selection Time	10 sec max.	Maximum time from when the TARG is turned on to the time the TARG can post the correct status and sense data for the TEST UNIT READY, INQUIRY or REQUEST SENSE command.
13	Reset to Selection Time	250 ms max.	Maximum time from when the RESET condition (hard RESET) is released to the time the TARG can post the correct status and sense data for the TEST UNIT READY, INQUIRY or REQUEST SENSE command.
14	Reset Hold Time	25 $\mu$ s min.	The minimum time during which the RST signal must be held true to create a RESET condition. A maximum time is not defined.
15	Selection Abort Time	200 $\mu$ s max.	In a SELECTION or RESELECTION phase, the maximum allowable period between the time the SCSI device recognizes itself as selected and the time it replies with a BSY signal.
16	Selection Timeout Delay	250 ms min. [Recommended value]	In a SELECTION or RESELECTION phase, the minimum time during which the INIT or TARG waits for a BSY signal from the SCSI device to be selected before it initiates timeout processing.

**Table 7.7 Timing specifications (3 of 3)**

No.	Name	Standard	Timing specification
17	Transfer Period	50 ns	In synchronous data transfer mode, the minimum time (minimum repetition time) from the leading edge of an REQ signal to the leading edge of the next REQ signal or from the leading edge of an ACK signal to the leading edge of the next ACK signal. The actual value is defined using a SYNCHRONOUS DATA TRANSFER REQUEST message exchanged between the INIT and TARG.

**Table 7.8 SCSI BUS Timing specifications**

No.	Name	Synchronous data transfer mode			Asynchronous data transfer mode
		Fast-20	Fast-SCSI	SCSI-1	
1	Arbitration Delay	2.4μs	2.4μs	2.4μs	2.4μs
2	Bus Clear Delay	800ns	800ns	800ns	800ns
3	Bus Free Delay	800ns	800ns	800ns	800ns
4	Bus Settle Delay	400ns	400ns	400ns	400ns
5	Cable Skew Delay	3ns	4ns	4ns	4ns
6	Data Release Delay	400ns	400ns	400ns	400ns
7	Receive Assertion Period	11ns	22ns	70ns	—
8	Receive Hold Time	11.5ns	25ns	25ns	—
9	Receive Negation Period	11ns	22ns	70ns	—
10	Receive Setup Time	6.5ns	15ns	15ns	—
11	Reset Hold Time	25ns	25ns	25ns	25ns
12	Selection Abort Time	200ns	200ns	200ns	200ns
13	Selection Time-out Delay	250ns	250ns	250ns	250ns
14	System Deskew Delay	15ns	20ns	45ns	45ns
15	Transfer Period during Synchronous Data Transfer Phases	50ns	100ns	200ns	—
16	Transmit Assertion Period	15ns	30ns	80ns	—
17	Transmit Hold Time	16.5ns	33ns	53ns	—
18	Transmit Negation Period	15ns	30ns	80ns	—
19	Transmit Setup Time	11.5ns	23ns	23ns	—

## 7.6 Bus Phases

The SCSI bus must be in one of the following eight phases:

- BUS FREE phase
  - ARBITRATION phase
  - SELECTION phase
  - RESELECTION phase
  - COMMAND phase
  - DATA phase
  - STATUS phase
  - MESSAGE phase
- } INFORMATION TRANSFER phase

The SCSI bus can never be in more than one phase at any given time.

Note: In the following bus phase definition, signals are false unless otherwise defined. Signals on the timing charts are assumed to be positive logic.

### 7.6.1 BUS FREE phase

No SCSI device uses the bus during a BUS FREE phase. SCSI devices shall detect the BUS FREE phase after SEL and BSY signals are both false for at least Bus Settle Delay.

SCSI devices which have detected the BUS FREE phase shall release all bus signals within Bus Clear Delay after BSY and SEL become false for a Bus Settle Delay. If an SCSI device requires more than Bus Settle Delay to detect the BUS FREE phase, it shall release all bus signals within the following period (t):

$$t = (\text{Bus Clear Delay}) - (\text{Period required for BUS FREE phase detection}) \\ + (\text{Bus Settle Delay})$$

The maximum time allowed for releasing the bus after both SEL and BSY becomes false is 1.2  $\mu$ s.

Figure 7.9 shows the BUS FREE phase.



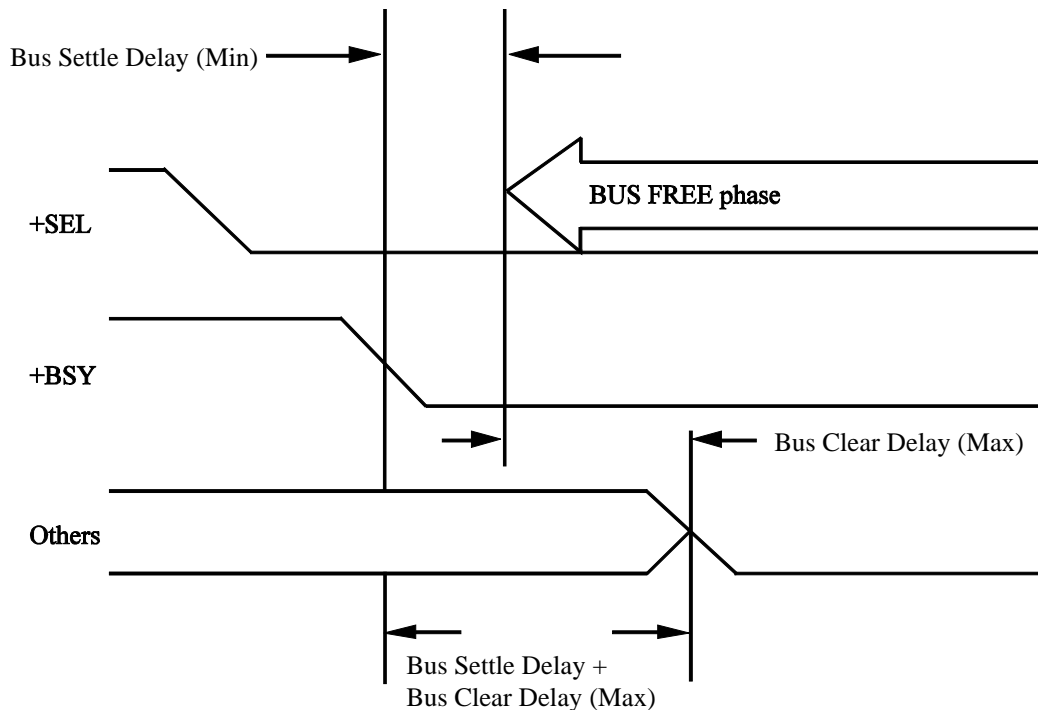

**Figure 7.9 BUS FREE phase**

Transition to a BUS FREE phase occurs when the TARG stops the BSY signal in one of the following events:

- When the RESET condition has been detected
- When the TARG has received ABORT message
- When the TARG has received a BUS DEVICE RESET message
- When the TARG has sent a DISCONNECT message normally
- When the TARG has sent a COMMAND COMPLETE message normally

If a SELECTION or RESELECTION phase is terminated unsuccessfully, the SCSI bus enters a BUS FREE phase. This BUS FREE phase is generated when the SEL signal becomes false.

In cases other than the above, if the TARG negates the BSY signal to enter a BUS FREE phase, the TARG informs the INIT that it has detected an ERROR condition on the SCSI bus. The TARG can enter a BUS FREE phase forcibly regardless of the ATN signal status; the INIT must treat that phase transition as indicating abnormal end of a command. The TARG clears all retained data or status and terminates the command being executed. It can then create sense data indicating the detailed error condition. If the INIT detects a BUS FREE phase when it is not expected, it should issue a REQUEST SENSE command to read the sense data.

## 7.6.2 ARBITRATION phase

The ARBITRATION phase allows one SCSI device to gain control of the SCSI bus so that an INIT starts the SELECTION phase or a TARG starts the RESELECTION phase.

Implementation of the ARBITRATION phase is a system option. This phase is required for system that has two or more INITs or uses the RESELECTION phase. The procedure to obtain control of the SCSI bus is as follows (see Figure 7.10):

- 1) The SCSI device shall wait for a BUS FREE phase (see Subsection 7.6.1).
  - 2) The SCSI device shall wait at least Bus Free Delay after Bus Free phase detection.
  - 3) Then the SCSI device that arbitrates the bus asserts the DATA BUS bit corresponding to its own SCSI ID and BSY signal within Bus Set Delay after last observation of the BUS FREE phase (\*1).
  - 4) After waiting at least Arbitration Delay since the SCSI device asserted the BSY signal, the SCSI device shall examine the value on the DATA BUS to determine the priority of the bus arbitration. (The priority of the bus arbitration is in the descending order of data bus bit numbers; the highest priority is DB7 (ID#7) and the lowest priority is DB0 (ID#0)).
    - When the SCSI device detects any ID bit which is assigned higher priority than its own SCSI ID, the SCSI device shall release its signals (BSY and its SCSI ID), then may return to step 1). (The SCSI device #1 in Figure 7.10 has lost the arbitration.)
    - The SCSI device which detects no higher SCSI ID bit on the DATA BUS can obtain the bus control, then it shall assert SEL signal. (The SCSI device #7 in Figure 7.10 has won the arbitration.)
    - Any other SCSI device that is participating in the ARBITRATION phase shall release its signals within Bus Clear Delay after the SEL signal becomes true, then may return to step 1). (The SCSI device #3 in Figure 7.10 has lost the arbitration.)
  - 5) The SCSI device which wins arbitration (SCSI device #7 in Figure 7.10) shall wait at least Bus Clear Delay + Bus Settle Delay after asserting the SEL signal before changing any signal state.
- \*1: When an SCSI device sends its SCSI ID to the DATA BUS, it asserts only the bit at the position corresponding to its own ID and leaves the other seven bits false. The parity bit (DBP signal) is not driven or is driven true, rather than false. The parity bit on the DATA BUS is unpredictable during an ARBITRATION phase.

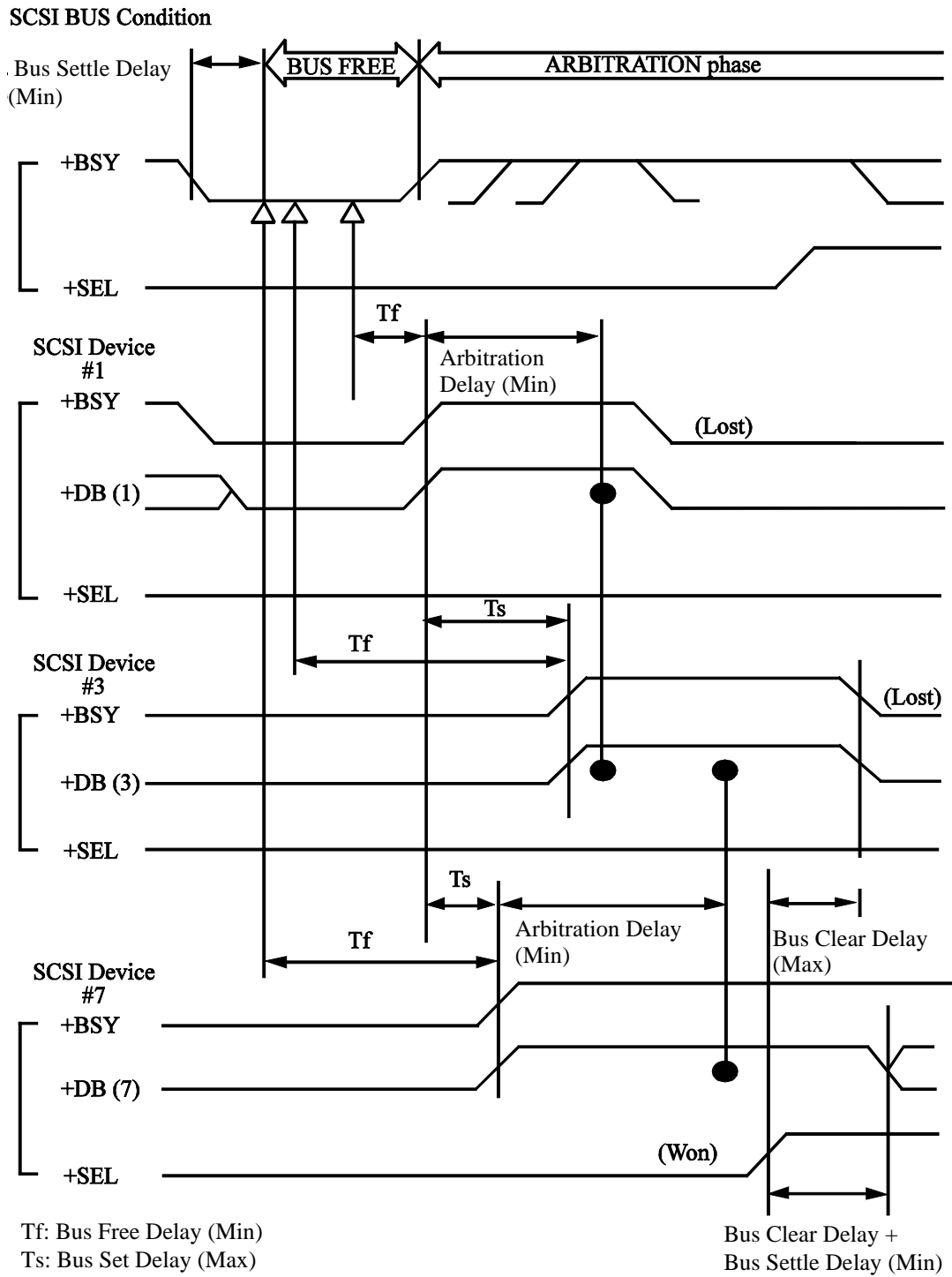

Figure 7.10 ARBITRATION phase

### 7.6.3 SELECTION phase

An INIT can select a TARG in the SELECTION phase.

Note: I/O signal is false during a SELECTION phase. (The I/O signal identifies the phase as SELECTION or RESELECTION).

#### (1) Start sequence without ARBITRATION phase

In systems with the ARBITRATION phase not implemented, the INIT starts the SELECTION phase in the following sequence (See Figure 7.11).

- 1) The INIT shall wait for at least Bus Clear Delay after BUS FREE phase detection.
- 2) The INIT then asserts its SCSI ID and that of the desired TARG on the data bus.
- 3) After waiting at least Deskew Delay  $\times$  2, the INIT asserts the SEL signal and waits for a response from the TARG (BSY signal).

#### (2) Start sequence with ARBITRATION phase

In systems with ARBITRATION phase implemented, the INIT starts the SELECTION phase in the following sequence (See Figure 7.11).

- 1) The INIT shall wait for at least Bus Clear Delay + Bus Settle Delay after turning SEL signal on during the ARBITRATION phase.
- 2) The INIT then asserts its SCSI ID and that of the desired TARG on the data bus.

At this time, the SCSI device becomes an INIT without driving the I/O signal.

- 3) The INIT releases the BSY signal after waiting at least Deskew Delay  $\times$  2. The INIT shall then wait at least Bus Settle Delay before looking for the response from the TARG (BSY signal).

#### (3) Response sequence

When the SCSI device (TARG) detects that the SEL signal and the data bus bit (DBn) corresponding to its SCSI ID are true and the BSY and I/O signals are false for more than Bus Settle Delay, it must recognize that itself is selected by the SELECTION phase. At this time, the selected TARG may sample all bits on the data bus to identify the INIT's SCSI ID.

The TARG must respond to the INIT by making the BSY signal true within Selection Abort Time after detecting that itself is selected. If the SCSI ID with three or more bits is detected on the data bus or a parity error is detected in the system making the data bus parity bit effective, the TARG must respond to the SELECTION phase.

The values on the DATA BUS can be changed after this time.

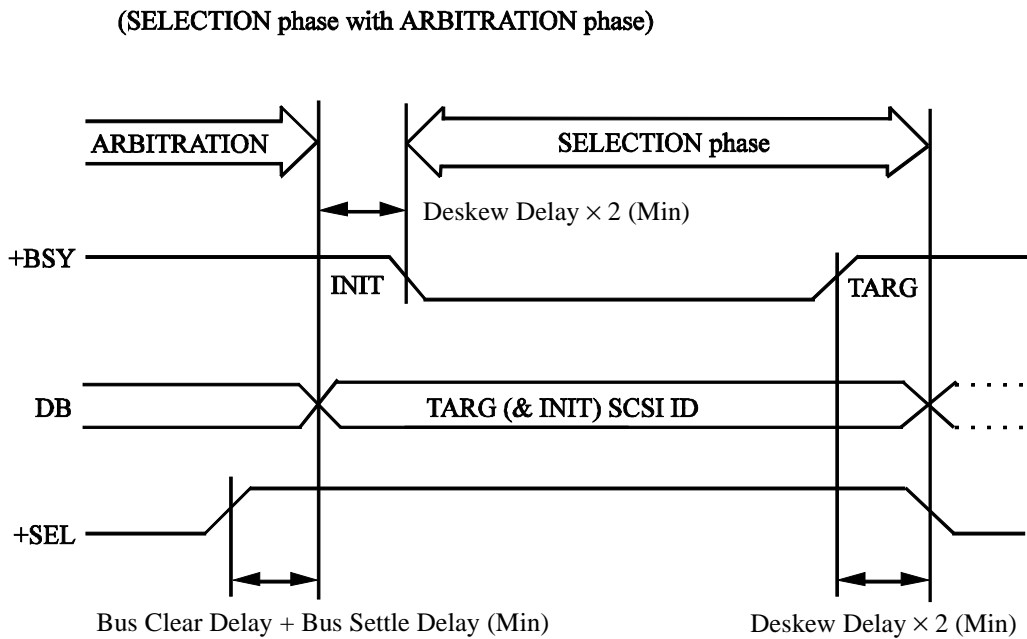
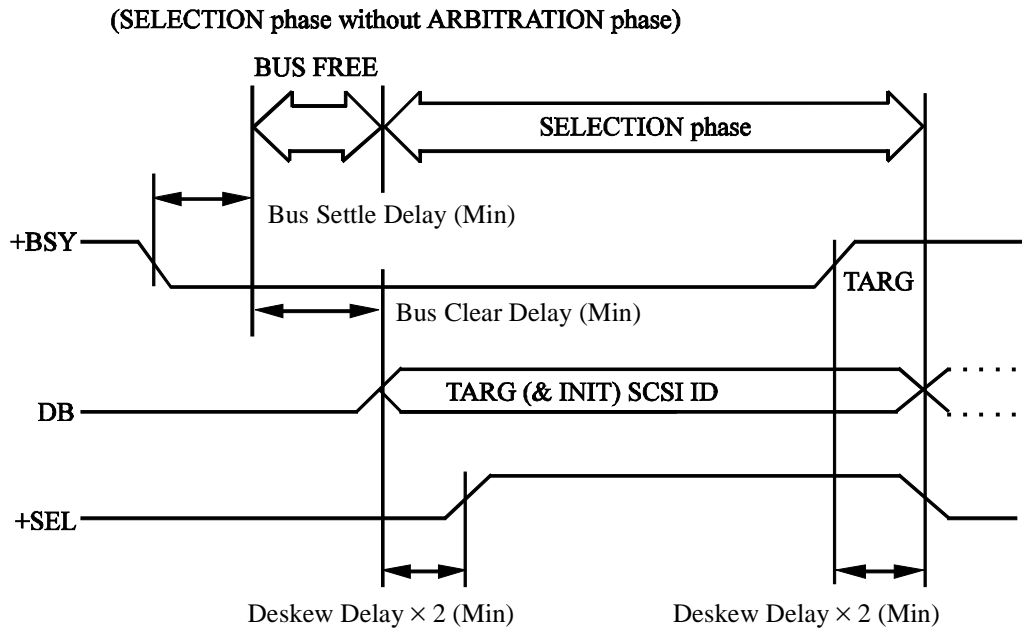

Figure 7.11 SELECTION phase

(4) Timeout procedure

If the INIT cannot detect the response from TARG when the Selection Timeout Delay (or longer) has passed after starting the SELECTION phase, the timeout procedure shall be performed through one of the following schemes:

- The INIT asserts the RST signal and creates the RESET condition.
- The INIT maintains SEL signal true and releases the data bus (SCSI IDs). Subsequently, the INIT waits for the response from TARG for at least Selection About Time + Deskew Delay  $\times$  2. If no response is detected, the INIT releases the SEL signal allowing the SCSI bus to go to the BUS FREE phase. If the INIT detects the response from TARG during this period, the INIT considers the SELECTION phase to have completed normally.

#### 7.6.4 RESELECTION phase

The TARG selects an INIT during the RESELECTION phase. The RESELECTION phase can only be used in systems with ARBITRATION phase implemented.

The TARG reconnects the INIT using this RESELECTION phase when the TARG restarts the command processing that is in the disconnect state on the SCSI bus.

(1) Start sequence

A TARG performs the RESELECTION phase in the following sequence after obtaining control of the SCSI bus through the ARBITRATION phase:

- 1) The TARG waits at least Bus Clear Delay + Bus Settle Delay after asserting the SEL signal.
- 2) The TARG sends the SCSI ID of TARG itself and INIT and asserts the I/O signal. (The TARG can obtain control of the SCSI bus by asserting the I/O signal.)
- 3) The TARG releases the BSY signal after waiting at least Deskew Delay  $\times$  2, then wait at least Bus Settle Delay before looking for the response from the INIT (BSY signal).

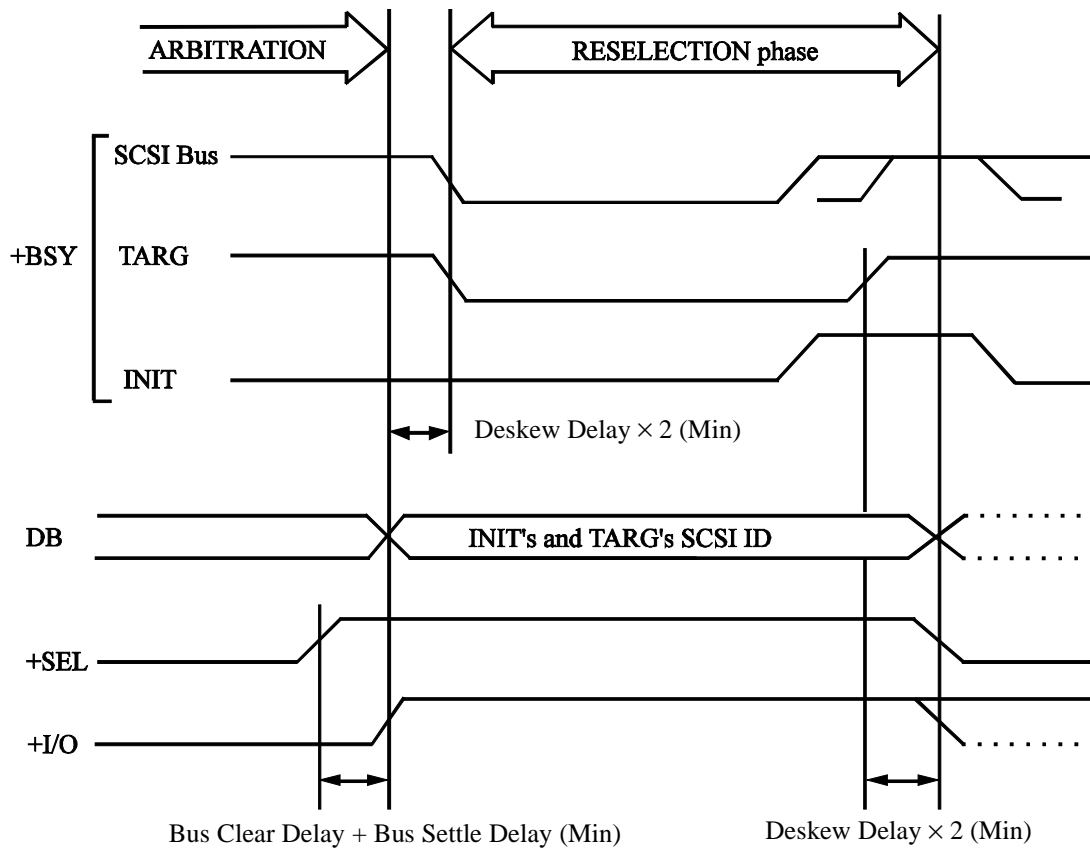

**Figure 7.12 RESELECTION phase**

(2) Response sequence

When the SCSI device (INIT) detects that the SEL signal, I/O signal and data bus bit (DB<sub>n</sub>) corresponding to the own SCSI ID are true and the BSY signal is false for Bus Settle Delay or more, the INIT shall recognize that the INIT itself is selected in the RESELECTION phase. At this time, the selected INIT performs sampling to identify the SCSI ID of the TARG that requests the reconnection.

The INIT shall respond to the TARG by asserting the BSY signal within Selection Abort Time.

When other than 2-bit SCSI ID is detected or when the parity error is detected on the system in which the parity bit of the data bus is valid, the INIT shall not respond to the RESELECTION phase.

After the TARG detects the response (BSY signal) from the INIT, the TARG asserts the BSY signal, then release the SEL signal after Deskew Delay  $\times$  2 or more. After this time, the TARG may change the I/O signal state and data bus value.

When the INIT detects that the SEL signal is false, the INIT stops sending the BSY signal.

### (3) Timeout procedure

If the TARG cannot detect a response from the INIT when the Selection Timeout Delay or longer has passed in the RESELECTION phase, the timeout procedure shall be performed through one of the following schemes:

- 1) The INIT asserts the RST signal to generate the RESET condition.
- 2) TARG terminates releasing SCSI ID to DATA BUS with maintaining SEL signal and I/O signal in TRUE status. Subsequently, the INIT waits for the response from TARG for at least Selection Abort Time + Deskew Delay  $\times$  2. If no response is detected, the INIT releases the SEL signal allowing the SCSI bus to go to the BUS FREE phase. If the INIT detects the response from TARG during this period, the INIT considers the SELECTION phase to have completed normally.

The ODD performs process 2) above as RESELECTION-phase time-out processing.

## 7.6.5 INFORMATION TRANSFER phases

COMMAND, DATA, STATUS, and MESSAGE phases are generally called INFORMATION TRANSFER phases. In these phases, data and control information are transferred between the INIT and the TARG through the data bus.

The type of INFORMATION TRANSFER phase is determined by the combination of C/D, I/O, and MSG signals (see Table 7.1). Since these three signals are specified by the TARG, phase transition is controlled by the SCSI device operating as a TARG. The INIT can request the TARG to initiate an MESSAGE OUT phase by sending an ATN signal. Besides, the TARG can change the bus phase to BUS FREE by ceasing transmission of the BSY signal.

Information transfer in an INFORMATION TRANSFER phase is controlled by REQ and ACK signals. The REQ signal is sent by the TARG to request data transfer, and the ACK signal is a response from the INIT. One pair of REQ and ACK signals causes one byte of information to be transferred. According to the method of sending an REQ signal and checking the replied ACK signal (REQ/ACK handshake), two data transfer modes are defined: synchronous and asynchronous.

During operation in an INFORMATION TRANSFER phase, the BSY signal must be kept true by the TARG. The SEL signal must be false. The TARG must establish the status of three signals C/D, I/O, and MSG which specify the phase type at least Bus Settle Delay before the leading edge of the REQ signal which requests transfer of the first byte. The TARG must maintain that status until the trailing edge of the ACK signal corresponding to the last byte in the phase (see Figure 7.13).



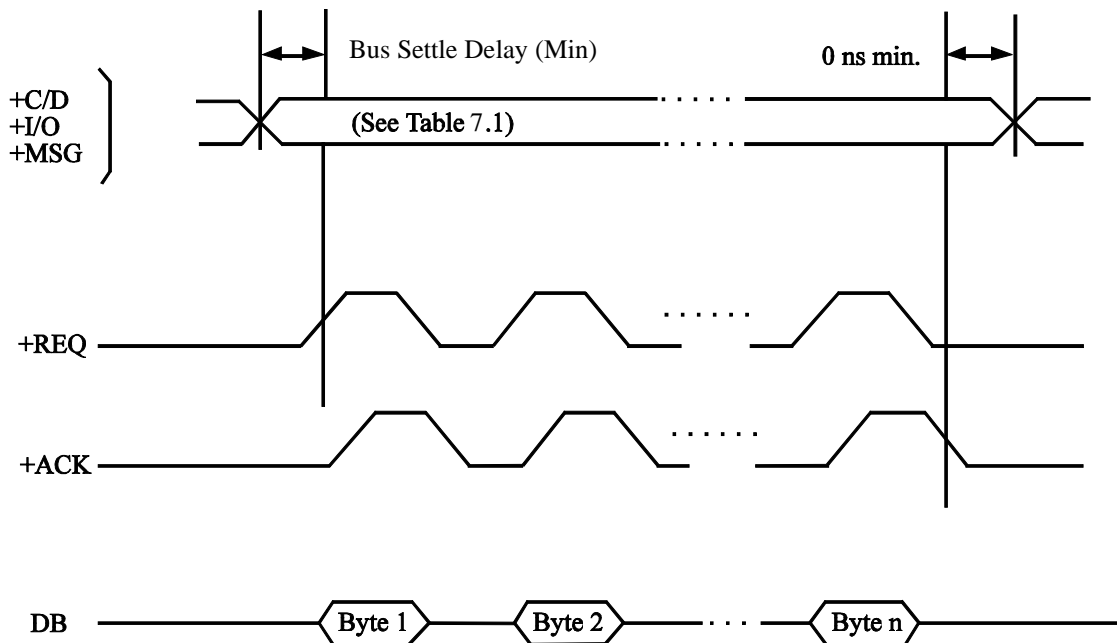

**Figure 7.13** INFORMATION TRANSFER phase (phase control)

### IMPORTANT

1. After the ACK signal becomes false during the INFORMATION TRANSFER phase, the TARG can begin to prepare for a new phase by changing the status of C/D, I/O, and MSG signals. The status of these three signals can change in any order or at once. The status of one signal may change more than once; however, the TARG should change the status of each signal only once.
2. Note that a new INFORMATION TRANSFER phase starts when the REQ signal that requests transfer of the first byte in the phase becomes true. The phase ends when one of C/D, I/O, or MSG signal changes after the ACK signal becomes false. The period between the time one phase ends and the time the REQ signal to initiate the next new phase becomes true is not defined.
3. The INIT can predict the next new phase (expected phase) from the status change of C/D, I/O, and MSG signals or from the type of the preceding execution phase executed. However, note that the expected phase does not come into effect until the REQ signal becomes true.

## (1) Asynchronous transfer

In asynchronous transfer mode, information transfer is controlled by the INIT and TARG which are checking the status transition (from false to true and vice versa) of REQ and ACK signals (interlock type). Asynchronous transfer can be used in all types of INFORMATION TRANSFER phase (COMMAND, DATA, STATUS, MESSAGE). Figure 7.14 shows the timing rule of the asynchronous transfer.

## a. Transfer from TARG to INIT

The TARG specifies the information transfer direction by the I/O signal. If the I/O signal is true, the information on the DATA BUS is transferred from the TARG to the INIT. Information transfer processing is as follows:

- 1) The TARG asserts the REQ signal at least Deskew Delay + Cable Skew Delay after sending valid information on the data bus (DB7 to DB0, P). It must maintain the state of DB7 to DB0, P until the ACK signal becomes true on the TARG.
- 2) INIT fetches the data from the data bus (DB7 to DB0, P) after the REQ signal becomes true. It asserts the ACK signal to report the completion of reception.
- 3) After the ACK signal becomes true on the TARG, the TARG negates the REQ signal. Thereafter, the TARG can change the data of the data bus.
- 4) The INIT negates the ACK signal after the REQ signal becomes false.
- 5) After the ACK signal becomes false, the TARG proceeds to transfer the next byte.

## b. Transfer from INIT to TARG

When the I/O signal is false, information on the data bus is transferred from the INIT to the TARG. Information transfer processing is as follows.

- 1) The TARG asserts the REQ signal to request the INIT to send information.
- 2) The INIT asserts the ACK signal at least Deskew Delay + Cable Skew Delay after sending valid information of the requested type on the data bus (DB7 to DB0, P). The information on the DATA BUS must be maintained until the REQ signal becomes false on the INIT.
- 3) The TARG fetches data from the data bus (DB7 to DB0, P) after the ACK signal becomes true and negates the REQ signal to report the completion of reception.
- 4) When the REQ signal becomes false on the INIT, the INIT negates the ACK signal. After that, the INIT can change data on the data bus.
- 5) The TARG proceeds to the transfer of the next byte after the ACK signal becomes false.

Timing rule for REQ and ACK signals

**Note:** Time is defined on SCSI connector pins on the ODD.

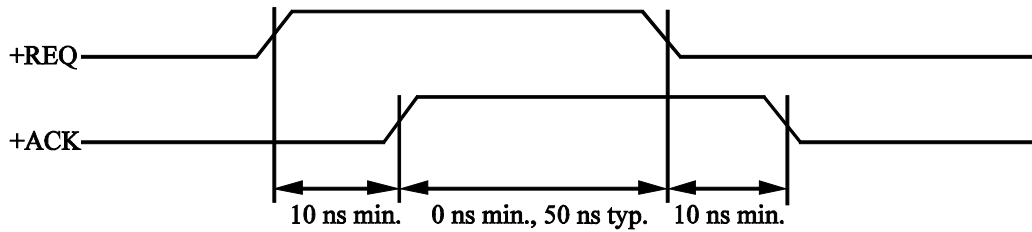

Transfer from TARG to INIT

**Note:** Time is defined on SCSI connector pins on the TARG.

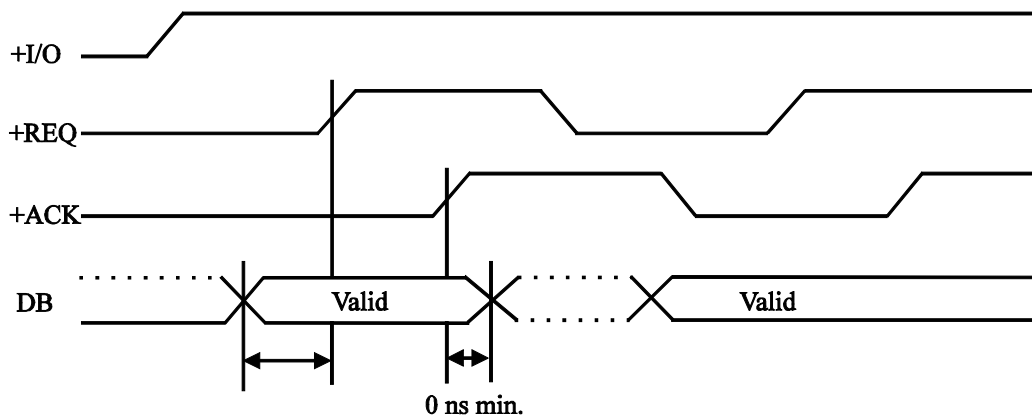

<sup>1</sup> Deskew Delay + Cable Skew Delay (Min)

Transfer from INIT to TARG

**Note:** Time is defined on SCSI connector pins on the INIT.

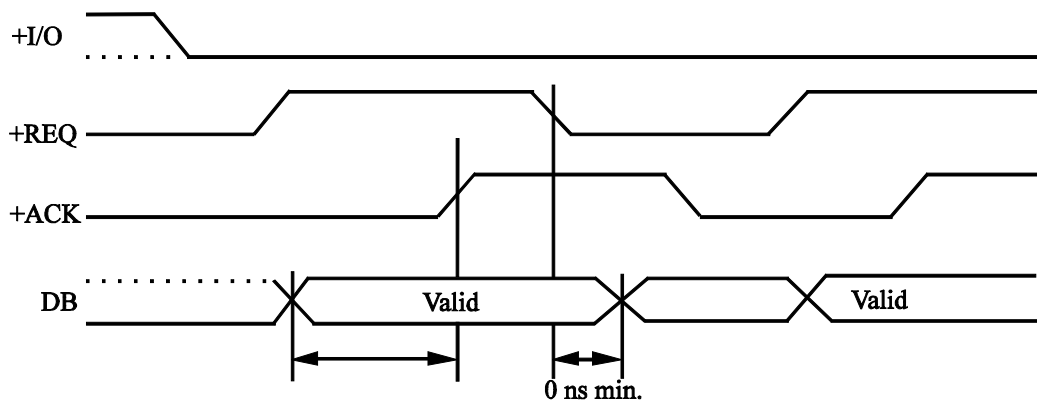

Deskew Delay + Cable Skew Delay (Min)

**Figure 7.14** Transfer in asynchronous mode

## (2) Synchronous mode

Information is transferred through offset-interlock of REQ/ACK handshake. Operation in this mode is only available for the DATA phase.

### **IMPORTANT**

The default data transfer mode is asynchronous mode. When power is first switched on, a RESET condition develops or a BUS DEVICE RESET message is exchanged, data transfer is performed in asynchronous mode until the message described below is exchanged, even if synchronous mode transfer is permitted with the setting terminal.

Before synchronous mode transfer can be used, a SYNCHRONOUS DATA TRANSFER REQUEST message must be exchanged between the INIT and TARG to define synchronous mode transfer between them. Then, the following transfer parameters are determined to define a range of possible transfer rates between the SCSI devices.

- REQ/ACK Offset: Number of REQ signals that the TARG can send before receiving the ACK signal.
- Transfer Period: Minimum repetition cycle of REQ and ACK signals.

The TARG can send more than one REQ pulse before receiving the ACK pulse from the INIT if the number of REQ pulses is within the range defined by the REQ/ACK Offset parameter. When the difference between the number of REQ pulses sent by the TARG and the number of ACK pulses received by the TARG reaches the number assigned to the REQ/ACK Offset parameter, the TARG must not send an REQ pulse until it receives the leading edge of the next ACK pulse. For normal termination of transfer in a DATA phase, the number of REQ pulses and the number of ACK pulses must be equal.

The TARG must satisfy the following timing requirements concerning the transmission of the REQ signal at the connector pin on the TARG:

- The minimum pulse width is Assertion Period.
- The minimum period from the trailing edge of a pulse to the leading edge of the next pulse is Negation Period.
- The period between the leading edges of a pulse and the next pulse is equal to or greater than the time defined by the Transfer Period parameter.

The INIT must respond to the TARG by sending as the same number of ACK pulses as the REQ pulses received from the TARG. It can send an ACK signal when it receives the leading edge of the corresponding REQ signal. The INIT must satisfy the following timing requirements concerning the transmission of the ACK signal at the SCSI connector pin on the INIT:

- The minimum pulse width is Assertion Period.
- The minimum period between the trailing edge of a pulse and the leading edge of the next pulse is Negation Period.
- The period between the leading edges of a pulse and the next pulse is equal to or greater than the time defined by the Transfer Period parameter.

Figure 7.15 shows the timing rule of the synchronous mode.

a. Transfer from TARG to INIT

The TARG specifies the data transfer direction by the I/O signal. If the I/O signal is true, data is transferred from the TARG to the INIT. Transfer processing is as follows:

- 1) After the TARG sends valid data on the data bus (DB7 to DB0, P), if a period elapses that is equal to or longer than the sum of the Deskew Delay time and the Cable Skew Delay time, the TARG sends the REQ pulse.
- 2) Starting with the rise of the REQ pulse, the TARG must hold values on the data bus valid for a period equal to or longer than the sum of the Deskew Delay time, the Cable Skew Delay time, and the Hold time. The TARG must send a REQ pulse having a width of at least the Assertion Period.
- 3) After compensating for the period defined in 2, the TARG transfers subsequent data in bytes within the range defined by the REQ/ACK Offset parameter.
- 4) Starting with the rise of the REQ pulse, the INIT reads data on the data bus (DB7 to DB0, P) within the Hold time. After reading the data, the INIT sends the ACK pulse as a receive completion notification.

b. Transfer from INIT to TARG

If the I/O signal is false, data is transferred from the INIT to the TARG. Transfer processing is as follows:

- 1) The TARG repeats the sending of the REQ pulse to request that data be sent until the number of REQ pulses reaches a value specified by the REQ/ACK Offset parameter.
- 2) The INIT transfers one byte of data each time the INIT receives the REQ pulse from the TARG. Upon receiving the REQ pulse, the INIT sends valid data on the data bus (DB7 to DB0, P). After the elapse of a period equal to or longer than the sum of the Deskew Delay time and the Cable Skew Delay time, the INIT sends the ACK pulse.
- 3) Starting with the rise of the ACK pulse, the INIT must hold the values on the data bus valid for a period equal to or longer than the sum of the Deskew Delay time, the Cable Skew Delay time, and the Hold time. The TARG must send an ACK pulse having a width of at least the Assertion Period.

- 4) Starting with the rise of the ACK pulse, the TARG reads data on the data bus (DB7 to DB0, P) within the Hold time.

(3) Time monitoring of ACK response wait

When the ODD operates as a TARG, wait time for ACK response to REQ can be monitored.

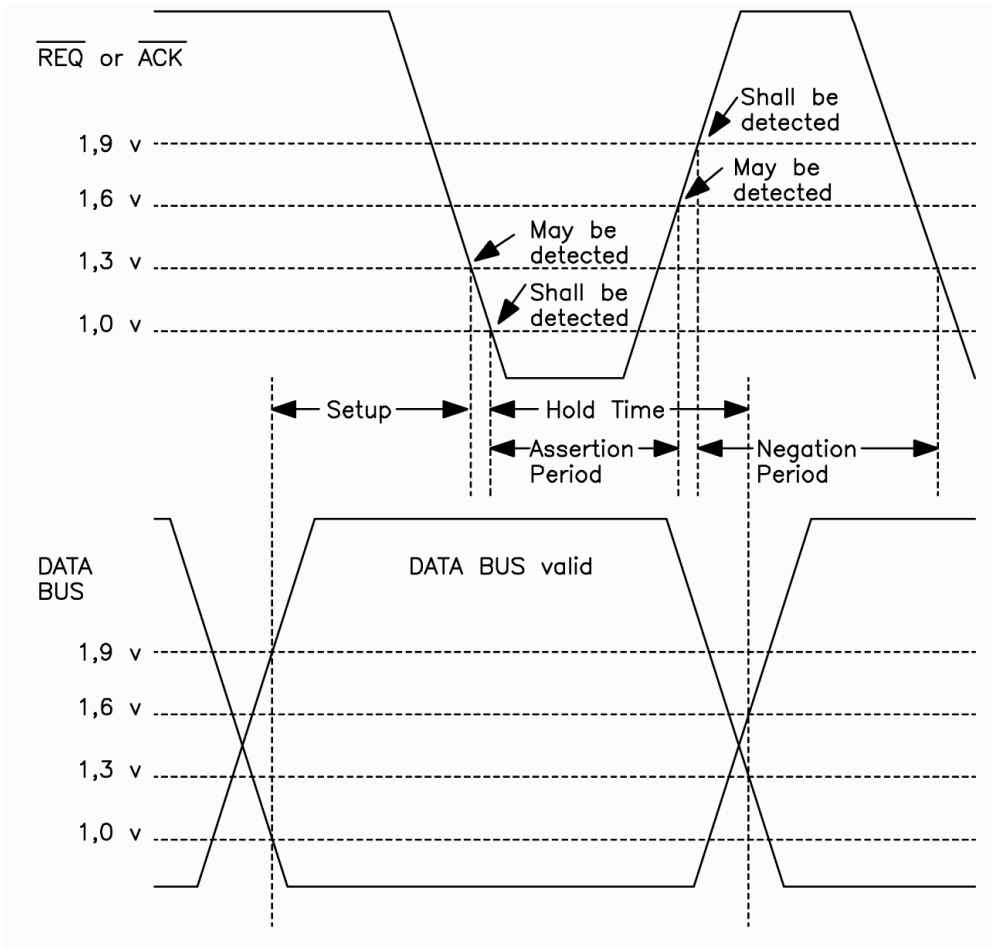

Figure 7.15 Transfer in synchronous mode

### 7.6.6 COMMAND phase

The COMMAND phase is a bus phase in which the TARG requests the INIT to transfer command information (CDB) to the TARG. The TARG keeps the C/D signal true and the I/O and MSG signals false during REQ/ACK handshaking in this phase.

### 7.6.7 DATA phase

The DATA phase is divided into DATA IN and DATA OUT phases according to the direction of data transfer. In a DATA phase, synchronous data transfer can be performed.

#### (1) DATA IN phase

In a DATA IN phase, the TARG requests to transfer data from the TARG to the INIT. The TARG keeps the I/O signal true and the C/D and MSG signals false during REQ/ACK handshaking in this phase.

#### (2) DATA OUT phase

In a DATA OUT phase, the TARG requests to transfer data from the INIT to the TARG. The TARG keeps the C/D, I/O, and MSG signals false during REQ/ACK handshaking in this phase.

#### (3) Data transfer rate in asynchronous mode

Figure 7.16 shows the REQ/ACK handshake timing that the ODD observes in a DATA phase where asynchronous transfer is used. The data transfer rate on the SCSI bus depends on sum of the ACK response time in the INIT and the signal delay time of the interface cable (T1 and T2 in Figure 7.16).

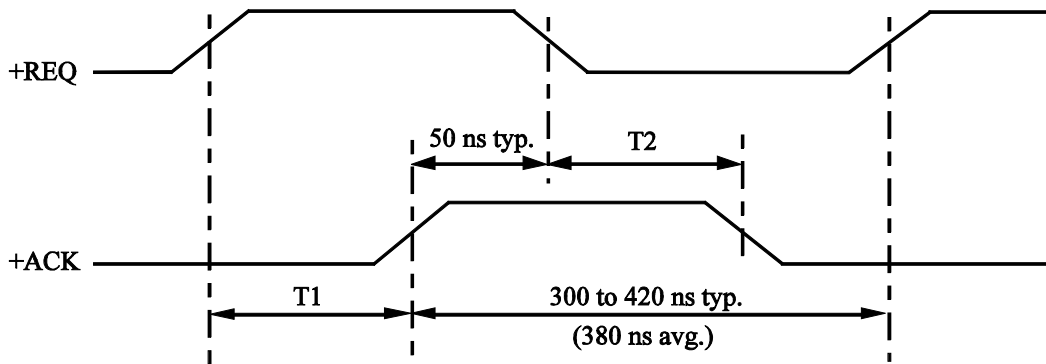

**Note:**

The time is determined by the corresponding pin of the SCSI connector on the ODD.

Cable length (m)	1	3	6
Average transfer rate (MB/s)	2.02	1.90	1.75

- The signal delay time over the cable is assumed to be 15 ns/m, including forward and backward travel.
- The delay from the REQ reception to the ACK response in the INIT is assumed to be 100 ns.
- Interval T2 in the figure is assumed to be 260 ns.

**Figure 7.16 Data transfer rate in asynchronous mode**

(4) Data transfer rate in synchronous mode

Table 7.9 lists parameters for synchronous data transfer that can be performed by the ODD. Values assigned to these parameters are determined by SYNCHRONOUS DATA TRANSFER REQUEST messages transferred between the INIT and TARG. In a system with more than one INIT, parameters may vary from one INIT to another. The data transfer rate is determined by the value assigned to the Transfer Period parameter. To maintain this transfer rate, however, an appropriate value must be assigned to the REQ/ACK Offset parameter considering the INIT's ACK pulse response performance and the interface cable length.

The formulas below give the approximate average data transfer rate that can be achieved on the SCSI bus in synchronous mode. (See Figure 7.17) The notation used in the formulas is as follows:



1) If  $(n \times T1) \geq (T2 + 700)$ ,

Average data transfer rate in SCSI =  $1000/T1$  (MB/s)

2) If  $(n \times T1) > (T2 + 700)$ ,

Average data transfer rate in SCSI =  $(n \times 1000)/(T2 + 700)$  (MB/s)

where,

n: Value assigned to REQ/ACK Offset parameter

T1: Value in ns assigned to Transfer Period parameter (see Table 7.9)

T2: Average time in ns from REQ<sub>i</sub> pulse transmission to corresponding ACK<sub>i</sub> response at the pertinent pins of the SCSI connector on the ODD

**Table 7.9 Parameters used for synchronous data transfer**

Parameter	Value	Transfer rate
REQ/ACK Offset	1 to 16	
Transfer Period (Minimum REQ Interval sent from ODD) (T1 in Figure 7.21)	X '0C' (50 ns)	Max. 20.0 MB/s* <sup>1</sup>
	X '12' (75 ns)	Max. 13.3 MB/s* <sup>1</sup>
	X '19' (100 ns)	Max. 10.0 MB/s* <sup>1</sup>
	X '25' (150 ns)	Max. 6.6 MB/s* <sup>1</sup>
	X '32' (200 ns)	Max. 5.0 MB/s* <sup>1</sup>
	X '3E' (250 ns)	Max. 4.0 MB/s* <sup>1</sup>
	X '4B' (300 ns)	Max. 3.3 MB/s* <sup>1</sup>

\*1. If a single-ended SCSI bus is used, the maximum transfer rate must be specified considering the bus configuration, the number of connected SCSI devices, and transmission characteristics.

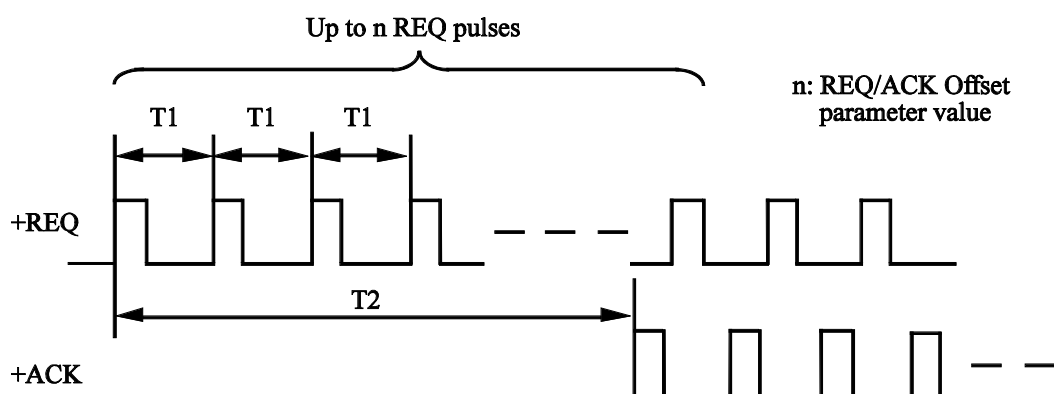

**Figure 7.17 Data transfer rate in synchronous mode**

### 7.6.8 STATUS phase

In a STATUS phase, the TARG requests to transfer status information from the TARG to the INIT. The TARG keeps the C/D and I/O signals true and the MSG signal false during REQ/ACK handshaking in this phase.

### 7.6.9 MESSAGE phase

The MESSAGE phase is divided into MESSAGE IN and MESSAGE OUT phases depending on the direction of message information transfer. In either phase, more than one message can be transferred. The first byte transferred in a MESSAGE phase must be a single-byte message or the first byte of a multiple-byte message. If the message consists of more than one byte, all bytes must be transferred in a single MESSAGE phase. For details of message types and their operation, see Chapter 5, "MCD3130SS, MCE3130SS, MCK3130SS, MCM3064SS, MCM3130SS Optical Disk Drives SCSI Logical Interface Specifications."

#### (1) MESSAGE IN phase

In a MESSAGE IN phase, the TARG requests to transfer message information from the TARG to the INIT. The TARG keeps the C/D, I/O, and MSG signals true during REQ/ACK handshaking in this phase.

#### (2) MESSAGE OUT phase

In a MESSAGE OUT phase, the TARG requests to transfer message information from the INIT to the TARG. The TARG keeps the C/D and MSG signals true and I/O signal false during REQ/ACK handshaking in this phase.

The TARG executes this phase in response to the ATTENTION condition (described in Subsection 7.7.1) created by the INIT, and must remain in the MESSAGE OUT phase.

**Note:** When the TARG returns a MESSAGE REJECT message to reject an invalid or incorrect message or when the TARG enters a BUS FREE phase as directed by a received message or returns a message (SYNCHRONOUS DATA TRANSFER REQUEST message, for example) in a prompt response to a received message, it can terminate the MESSAGE OUT phase regardless of whether the ATN signal is true or false.

When the TARG detects a parity error in the received message information, the TARG can request the INIT to retry message transmission by sending a REQ signal after sensing the ATN signal false without having to change the bus phase (that is, while remaining in the MESSAGE OUT phase). Upon receiving this REQ signal, the INIT must retransmit all of the same message bytes that were transmitted in the MESSAGE OUT phase in the same sequence. If the message consists of more than one byte, the INIT must make the ATN signal true before returning the ACK signal for the first byte and must keep it true until the last byte is transferred.

Unless a parity error is detected, the TARG can execute the received message immediately after its reception. If a parity error is detected, the TARG ignores that part of the message which has been received after the detection of the parity error. Suppose that when the INIT retransmits a series of messages in the MESSAGE OUT phase, the TARG has already executed some messages. In this event, the TARG must handle the received messages so that no logical contradiction will occur (for example, the TARG must ignore received messages that have already been executed).

If the TARG receives all message information normally without detecting a parity error, the TARG must enter an INFORMATION TRANSFER phase other than a MESSAGE OUT phase and must send at least one byte of information in order to advise the INIT that message transfer retry is unnecessary. However, for some types of message (ABORT and BUS DEVICE RESET, for example), the TARG can report the normal completion of message reception by entering a BUS FREE phase.

#### **7.6.10 Signal requirements concerning transition between bus phases**

When the SCSI bus is at a midpoint between two INFORMATION TRANSFER phases (during the period of bus phase transition), interface signals must satisfy the requirements below.

- 1) The status of the BSY, SEL, REQ, and ACK signals must not change.
- 2) The status of the ATN and RST signals can change within the range determined by the ATTENTION condition (see Subsection 7.7.1) or RESET condition (see Subsection 7.7.2).
- 3) The status of the C/D, I/O and MSG signals and the DATA BUS (DBn) can change. However, the direction of data transfer over the DATA BUS must satisfy the following rule. (See Figure 7.18.)
  - When changing the direction of transfer from Out (from INIT to TARG) to In (from TARG to INIT), the TARG must begin to drive the data bus (DBn) at least Data Release Delay + Bus Settle Delay after making the I/O signal true. The INIT must stop driving the data bus within Data Release Delay after the I/O signal becomes true.
  - When changing the direction of transfer from In (from TARG to INIT) to Out (from INIT to TARG), the TARG must stop driving the data bus (DBn) within Deskew Delay after making the I/O signal false.

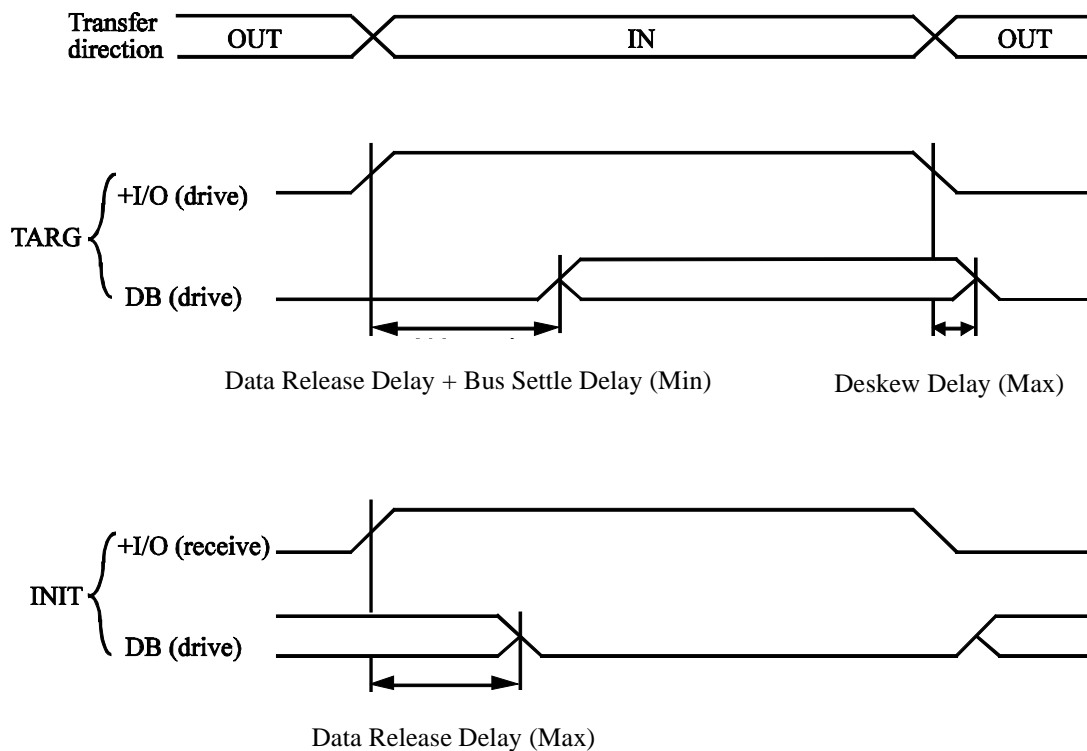

**Figure 7.18 Switching direction of transfer over the data bus**

### 7.6.11 Time monitoring feature

The ODD has a time monitoring feature for the SCSI bus to prevent hang-up of the SCSI bus in the case that the TARG cannot receive a response from the INIT in the RESELECTION or INFORMATION TRANSFER phase.

#### (1) Time monitoring in RESELECTION phase

The ODD monitors the time of the response (BSY signal) from the INIT in the RESELECTION phase. When the INIT does not send the BSY signal within a specified period, the ODD executes the timeout process (see Subsection 7.6.4) to free the SCSI bus and then executes the retry process (see Section 6.1) of the RESELECTION phase in "MCD3130SS, MCE3130SS, MCK3130SS, MCM3064SS, MCM3130SS Optical Disk Drives SCSI Logical Interface Specifications."

#### (2) Time monitoring in INFORMATION TRANSFER phase

The ODD monitors the timing of the ACK signal against the REQ signal in the INFORMATION TRANSFER phase. Time monitoring is executed during the following period:

- COMMAND, STATUS, or MESSAGE phase:

Time taken from the moment of sending the REQ signal of the first byte to the moment of completing the reception of the ACK signal of the last byte of the phase.

- 
- DATA phase:

Time taken for completing eight REQ/ACK handshakes (average).

Note: When the ACK signal is returned repeatedly within an interval of 500 ms or more, timeout may occur even if eight REQ/ACK handshakes on average had been terminated with the time listed in Table 7.10.

When timeout is detected, the ODD clears the command being executed and forces the SCSI bus into the BUS FREE phase (see Section 6.1) in "MCD3130SS, MCE3130SS, MCK3130SS, MCM3064SS, MCM3130SS Optical Disk Drives SCSI Logical Interface Specifications."

**Table 7.10 Setting value of SCSI time monitoring**

Monitoring time in INFORMATION TRANSFER phase	Monitoring time in RESELECTION phase	Number of retries in RESELECTION phase
About 30 sec	About 250 ms	10 times

## 7.7 Bus Conditions

Two types of asynchronous operations, an ATTENTION condition and a RESET condition, are provided to control and modify the bus phase transition sequence (bus condition).

### 7.7.1 ATTENTION condition

The ATTENTION condition allows an INIT to report that the INIT has messages to be sent to the TARG. The TARG receives a message from the INIT by executing the MESSAGE OUT phase. Figure 7.19 shows the ATTENTION condition.

#### (1) Generation and release of ATTENTION condition (INIT)

By making the ATN signal true, the INIT can generate the ATTENTION condition any time except during the ARBITRATION or BUS FREE phase.

Consider the generation of a new ATTENTION condition in the INFORMATION TRANSFER phase. To inform the TARG of the ATTENTION condition before the transition to the next new bus phase, the INIT must set the ATN signal true before  $\text{Deskew Delay} \times 2$  or more from the timing of setting the ACK signal false for the last byte being transferred in the current bus phase. If the ATN sending timing is delayed, the TARG may not be informed of the ATTENTION condition until the next bus phase. The INIT may not operate as it should.

When transferring message information in several bytes in the MESSAGE OUT phase, the INIT must keep the ATN signal true. The INIT can make the ATN signal false any time except while the ACK signal is true in the MESSAGE OUT phase. When transferring the last byte in the MESSAGE OUT phase, the INIT generally makes the ATN signal false during the period between the time the REQ signal becomes true and the time it returns the ACK signal. In this case, the INIT must set the ATN signal false before  $\text{Deskew Delay} \times 2$  or more from the time of setting the ACK signal true.

The INIT must make the ATN signal false before making the ACK signal true to transfer the last message byte if so specified for the particular type of message to the TARG. (See "MCD3130SS, MCE3130SS, MCK3130SS, MCM3064SS, MCM3130SS Optical Disk Drives SCSI Logical Interface Specifications.")

## (2) Response against ATTENTION condition (TARG)

The TARG must enter the MESSAGE OUT phase and respond to the ATTENTION condition under the following situations. After terminating the MESSAGE OUT phase and sending back a MESSAGE REJECT message, the TARG must reenter the MESSAGE OUT phase if the ATN signal is true.

- When the ATN signal becomes true in the COMMAND phase, the TARG must initiate the MESSAGE OUT phase immediately after the command (command descriptor block [CDB]) has completed the transfer of all or some bytes.
- When the ATN signal becomes true in the DATA phase, the TARG must enter the MESSAGE OUT phase immediately after the DATA phase. The TARG can enter the MESSAGE OUT phase at any time. (For example, the data transfer need not be terminated at a logical data block boundary.) The INIT must continue REQ/ACK handshaking (DATA phase) until the bus phase changes.
- When the ATN signal becomes true in the STATUS phase, the TARG must enter the MESSAGE OUT phase after the status byte transfer is completed.
- When the ATN signal becomes true in the MESSAGE IN phase, the TARG must enter the MESSAGE OUT phase immediately after transferring the current message.
- When the ATN signal becomes true in the SELECTION phase, the selected TARG must enter the MESSAGE OUT phase immediately after the SELECTION phase.
- When the ATN signal becomes true in the RESELECTION phase, the TARG must enter the MESSAGE OUT phase after the IDENTIFY message transmission is completed.

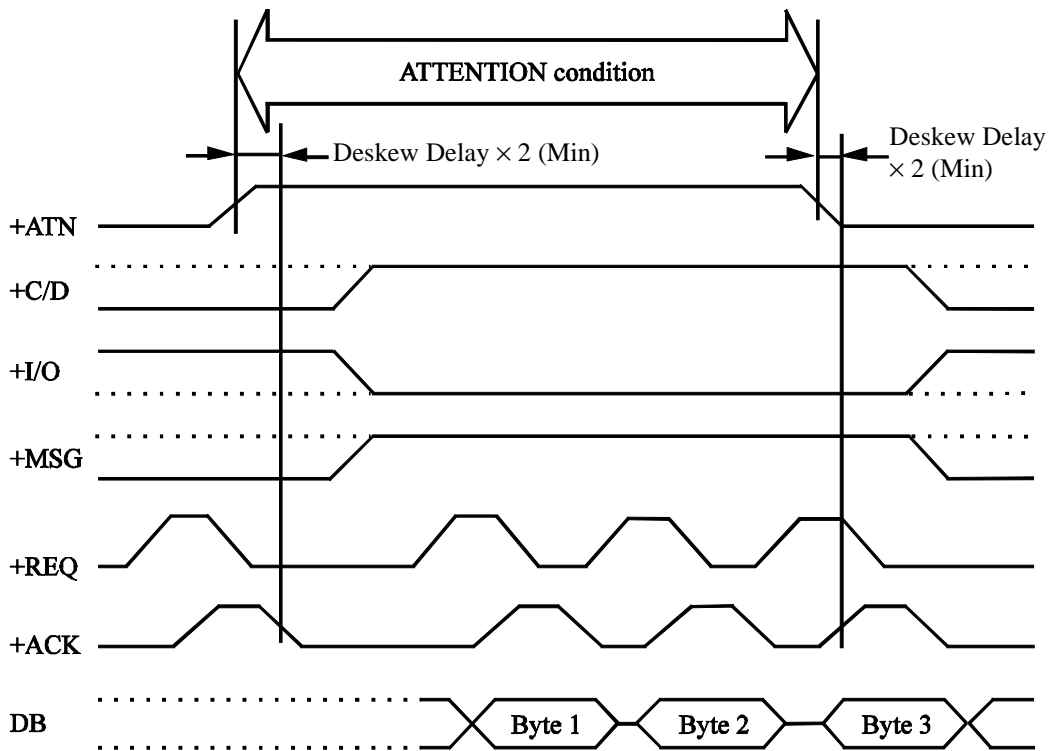

**Note:**

The time is specified at the SCSI connector terminal of the TARG.

**Figure 7.19 ATTENTION condition**

**IMPORTANT**

The ATTENTION condition generated by the INIT in the SELECTION phase determines the message level to be used in the command execution sequence. (Details are explained in Subsection 5.1.3. of “MCD3130SS, MCE3130SS, MCK3130SS, MCM3064SS, MCM3130SS OPTICAL DISK DRIVES SCSI LOGICAL INTERFACE SPECIFICATIONS.”) If the ATTENTION condition is not generated in the SELECTION phase, the TARG uses a COMMAND COMPLETE message only. The TARG does not respond to the ATTENTION condition even if it was generated in the subsequent bus phase. Therefore, the TARG does not enter the MESSAGE OUT phase.

**7.7.2 RESET condition**

The RESET condition allows all SCSI devices to immediately release the bus. RESET has higher priority than any other phases and bus conditions. Any SCSI device can generate the RESET condition at any time by keeping the RST signal true for 25 μs (Reset Hold Time) or more. The state of all bus signals except RST signals are undefined during the RESET condition.



All SCSI devices must deactivate all the bus signals except RST signals and release the bus within 800 ns (Bus Clear Delay) after the RST signal becomes true. After the RESET condition, the SCSI bus must enter the BUS FREE phase. Figure 7.20 shows the RESET condition.

The following are the ODD operations when the RESET condition is detected.

- 1) All commands including those being executed and those in a stack are cleared.
- 2) The reserve status of the disk drive is reset.
- 3) The operation mode set by a message or the command is initialized as when power is turned on.

The current value in the parameter set by a MODE SELECT command is initialized to the saved value last established. If the value is not saved, it is initialized to the default value.

Parameters defined for synchronous transfer between the ODD and SCSI device is cleared. The mode defined for data transfer among all SCSI devices is initialized to asynchronous mode.

- 4) The UNIT ATTENTION condition is generated for all SCSI devices.
- 5) The sense data is no longer retained and is cleared.
- 6) All data read into the data buffer in advance by the read-ahead cache feature is invalidated.

### **IMPORTANT**

1. The ODD does not generate a RESET condition.
2. The ODD provides only the "hard" RESET condition specified by the SCSI standard.
3. Reset Hold Time is specified to guarantee that any SCSI device can recognize the occurrence the RESET condition. On the ODD, even if the pulse width is less than 25  $\mu$ s, the RESET condition is effective.

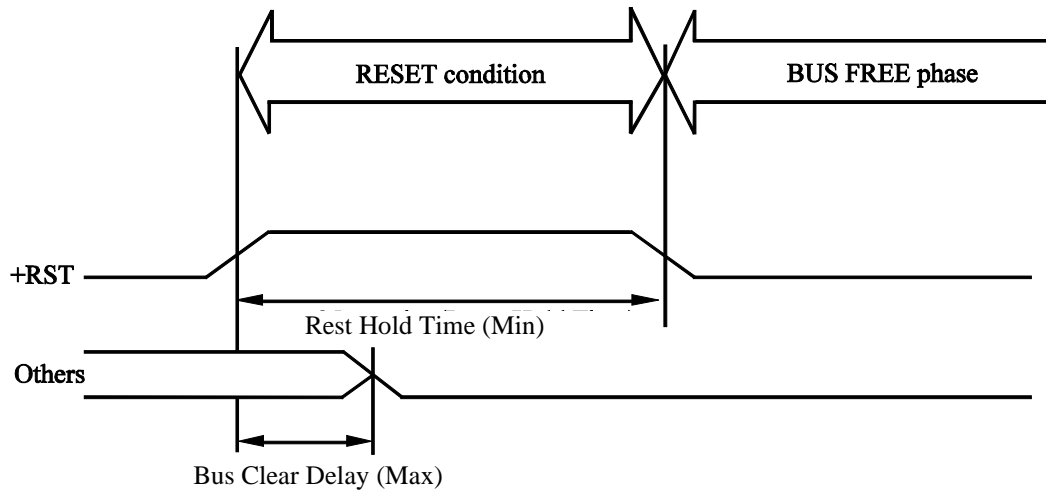

**Figure 7.20**     **RESET condition**

## 7.8 Bus Sequence

SCSI bus phases are switched in the specified sequence according to the command operation executed in the TARG. After a TARG has asserted the BSY signal in the SELECTION or RESELECTION phase, the bus phase sequence other than ATTENTION condition and RESET condition is controlled by the TARG.

All bus phases can be aborted through the RESET condition so that the BUS FREE phase is always created. Also, any other phase can be followed by the BUS FREE phase.

**Note:** The TARG can enter the BUS FREE phase in order to report an error condition. For details, see Subsection 7.6.1.

Figure 7.21 shows the allowable bus phase sequence applied to systems without the ARBITRATION phase and systems with the ARBITRATION phase. Figure 7.22 provides an example of bus phase sequence during single command execution.

### **IMPORTANT**

the ARBITRATION phase, systems with the ARBITRATION phase, systems with the MESSAGE OUT phase, and systems without the MESSAGE OUT phase. The generation of the ATTENTION condition determines whether or not systems use the MESSAGE OUT phase. If the ATTENTION condition is not generated, the TARG assumes that the INIT is supporting only a COMMAND COMPLETE message and the TARG operates so that it will not use other messages in the subsequent command execution sequence. The ATN signal status is ignored; therefore, the TARG does not enter the MESSAGE OUT phase.

When ARBITRATION is used with MESSAGE OUT

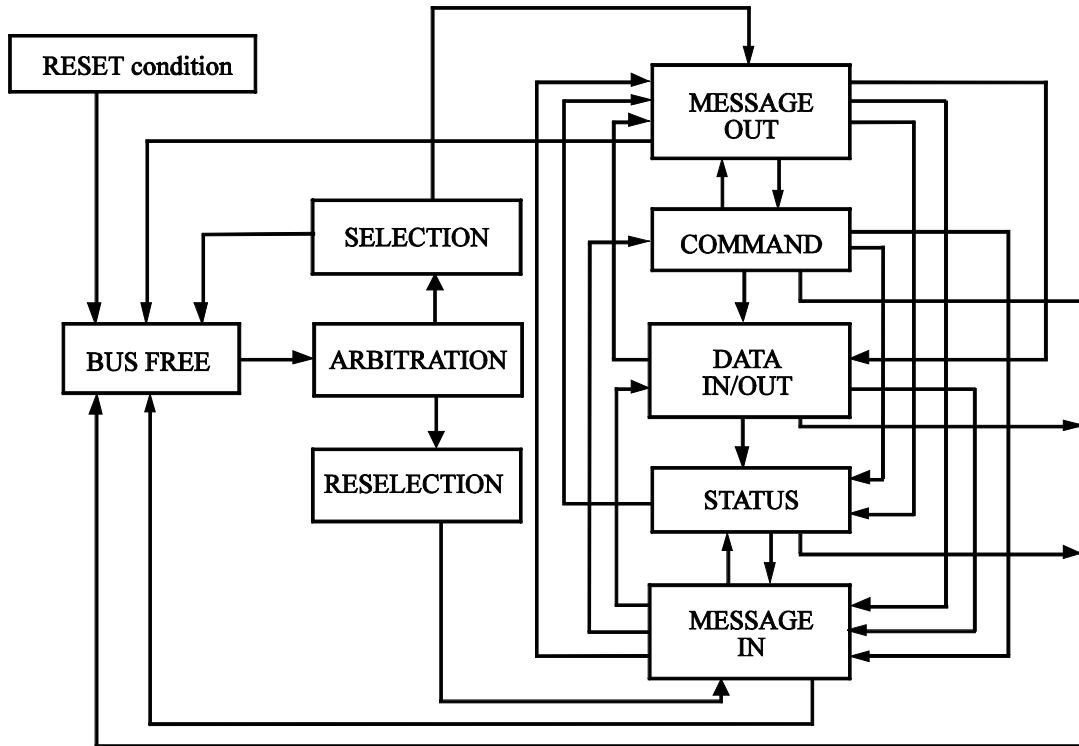

When ARBITRATION is used without MESSAGE OUT

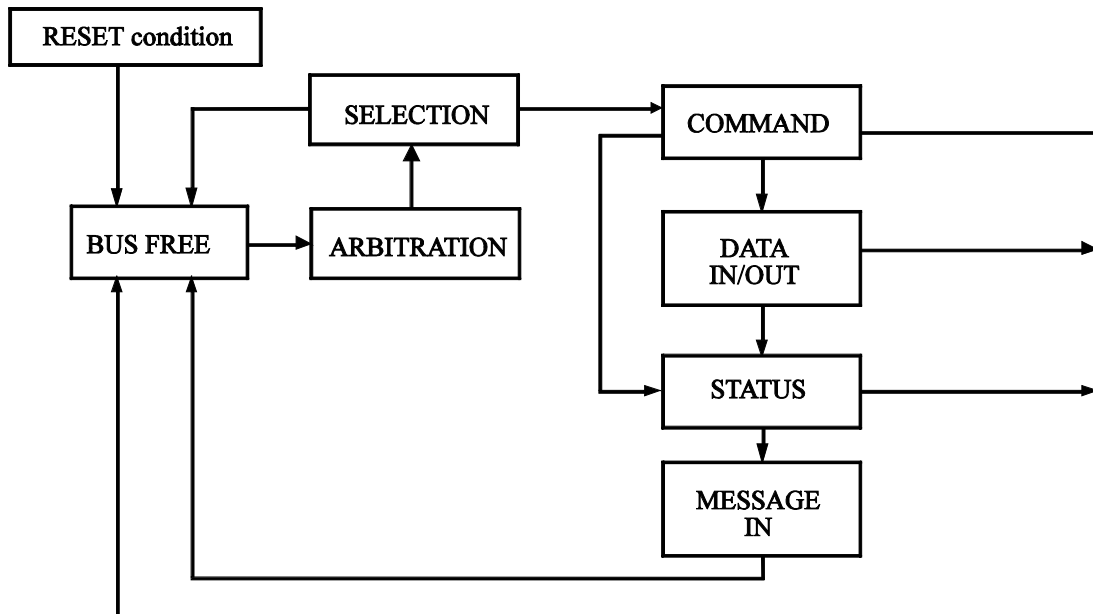
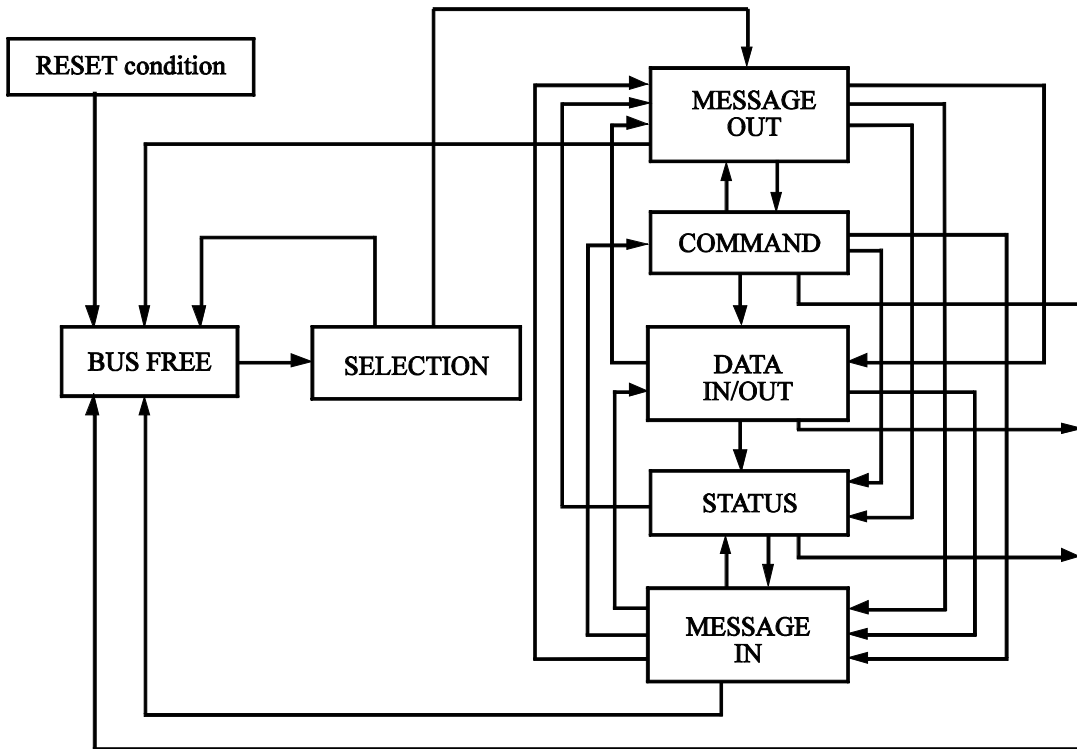

Figure 7.21 Bus phase sequence (1 of 2)

When ARBITRATION is not used with MESSAGE OUT



When ARBITRATION is not used without MESSAGE OUT

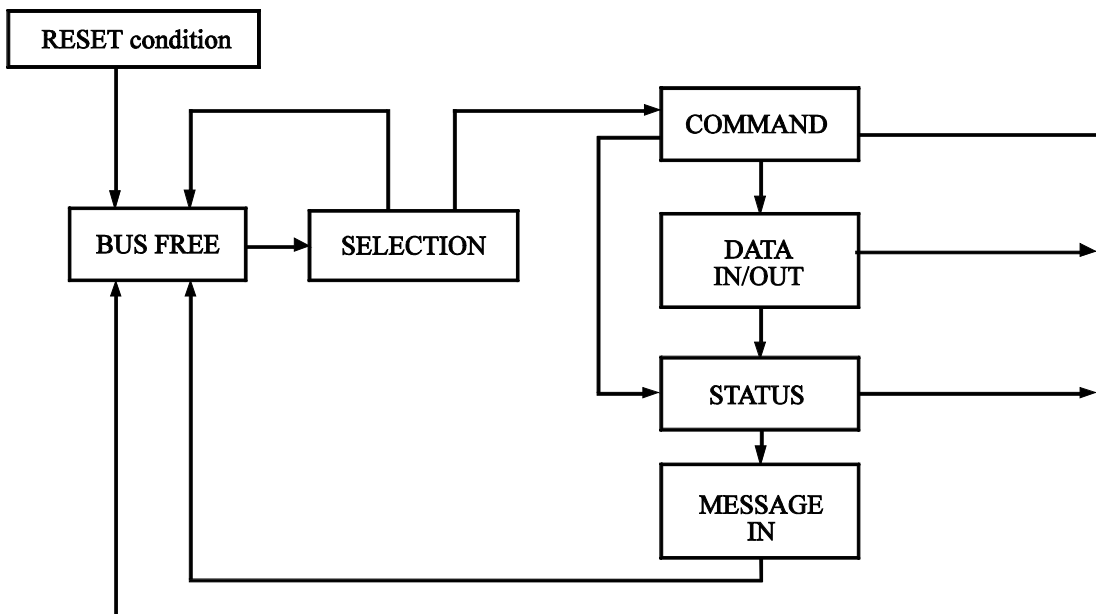

Figure 7.21 Bus phase sequence (2 of 2)

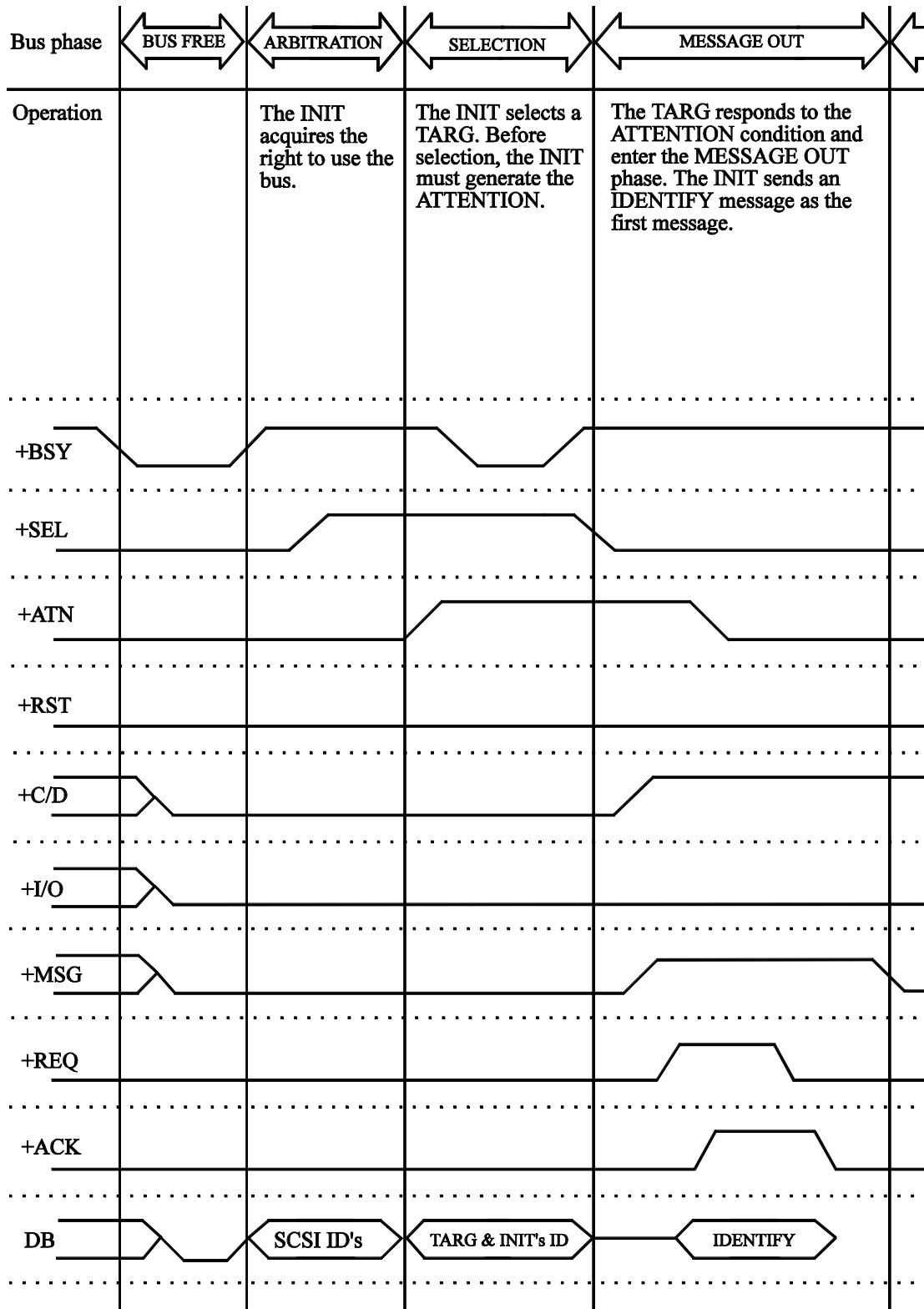

Figure 7.22 Example of bus phase transition on execution of a single command (1 of 5)

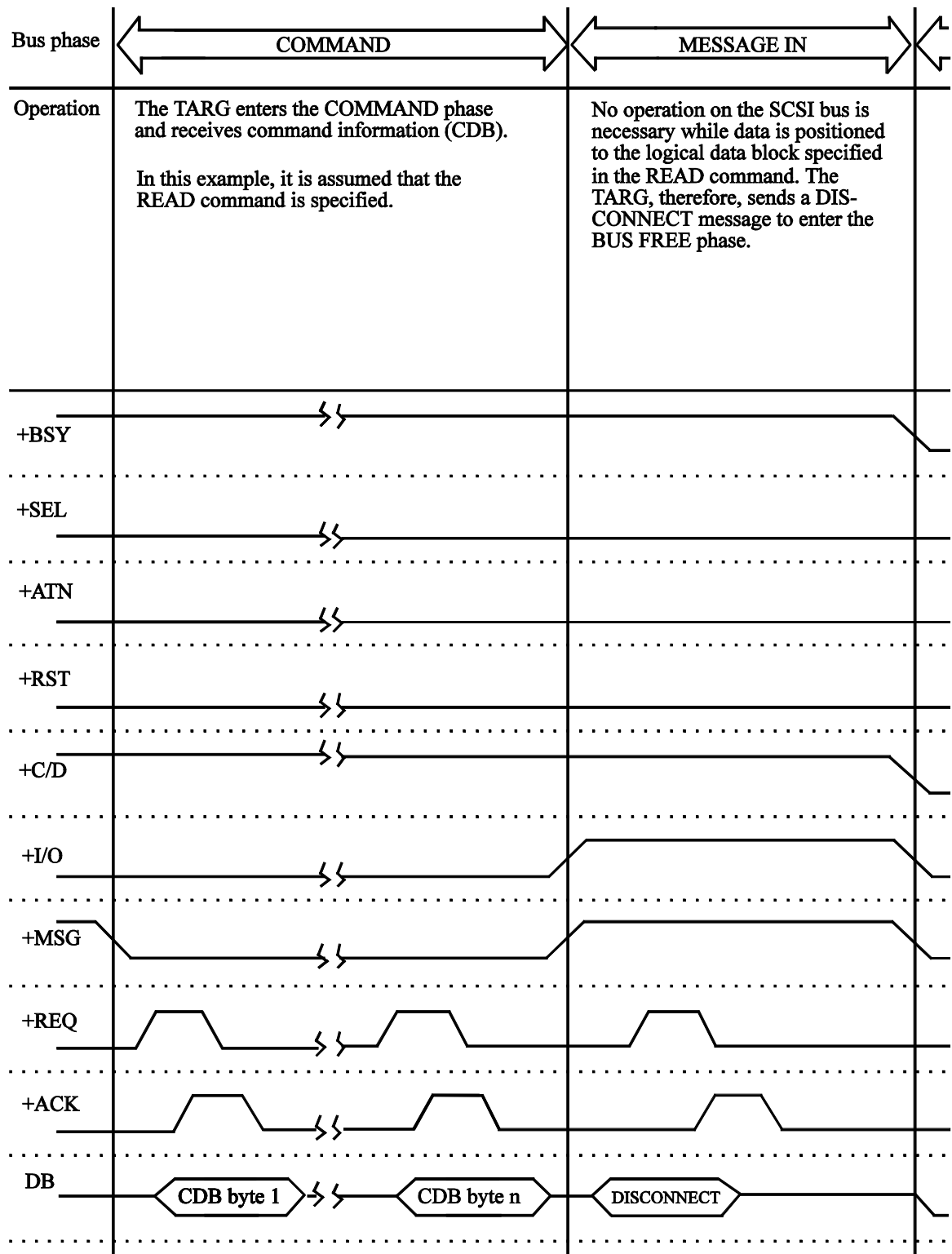

Figure 7.22 Example of bus phase transition on execution of a single command (2 of 5)

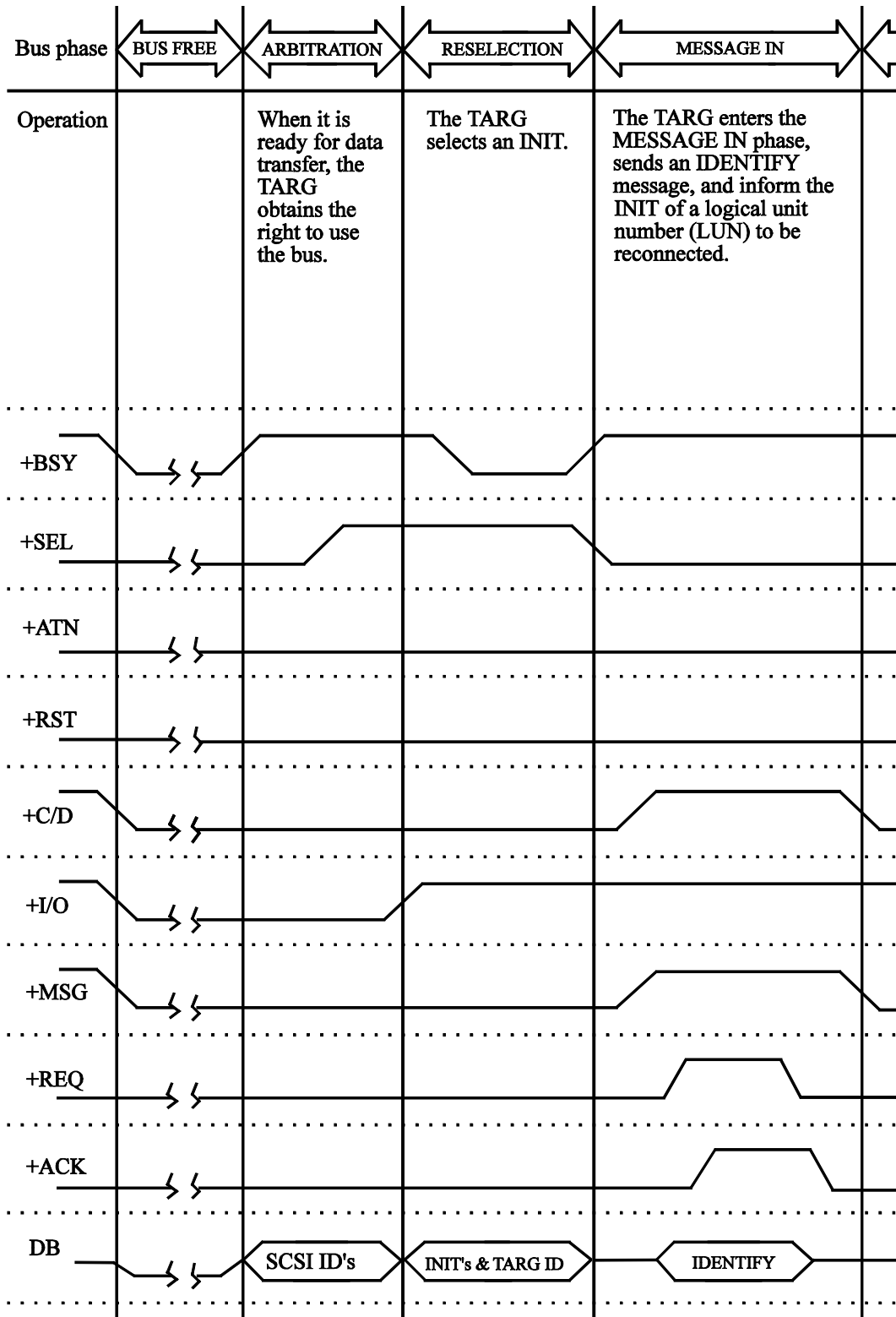

Figure 7.22 Example of bus phase transition on execution of a single command (3 of 5)



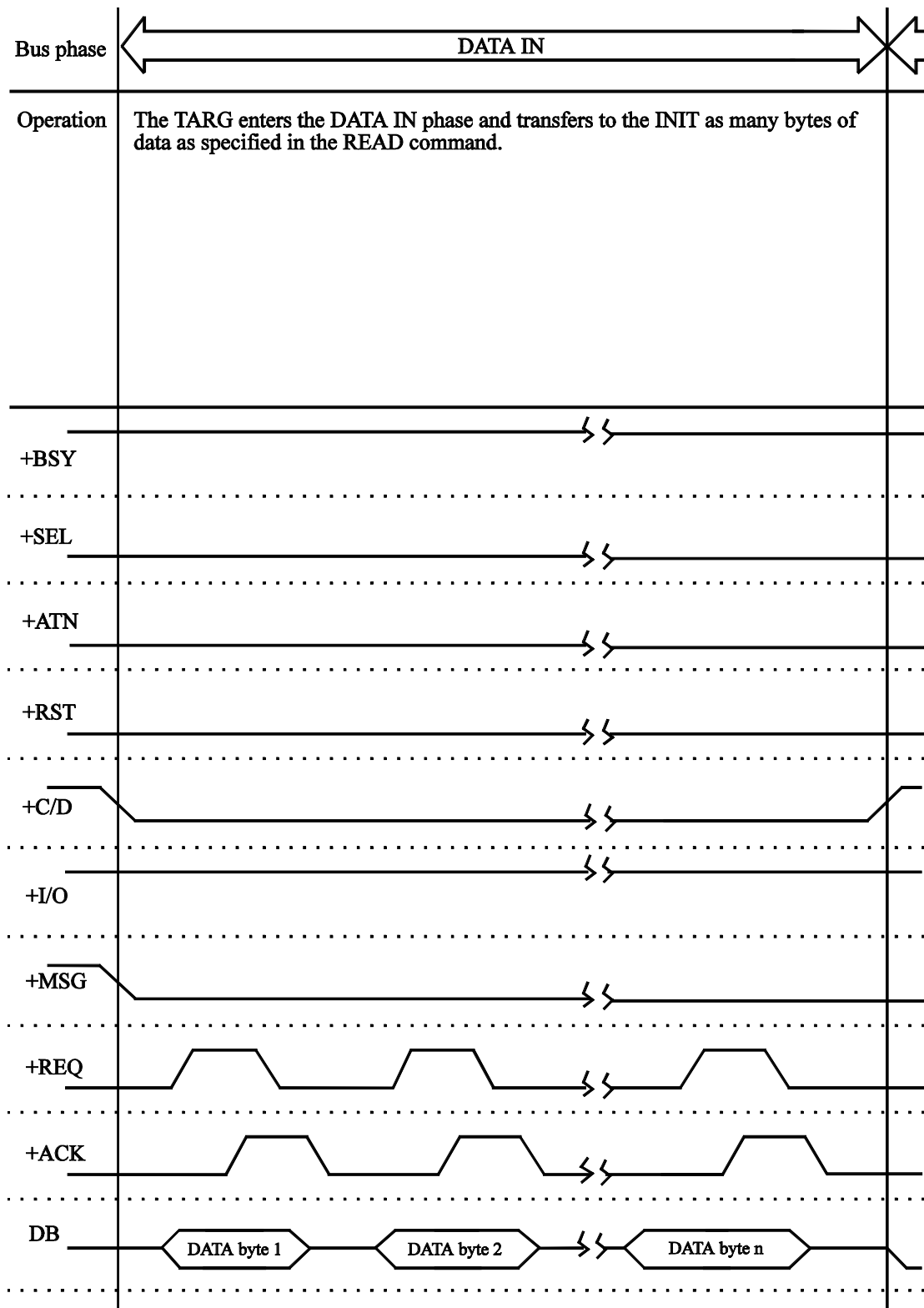

Figure 7.22 Example of bus phase transition on execution of a single command (4 of 5)

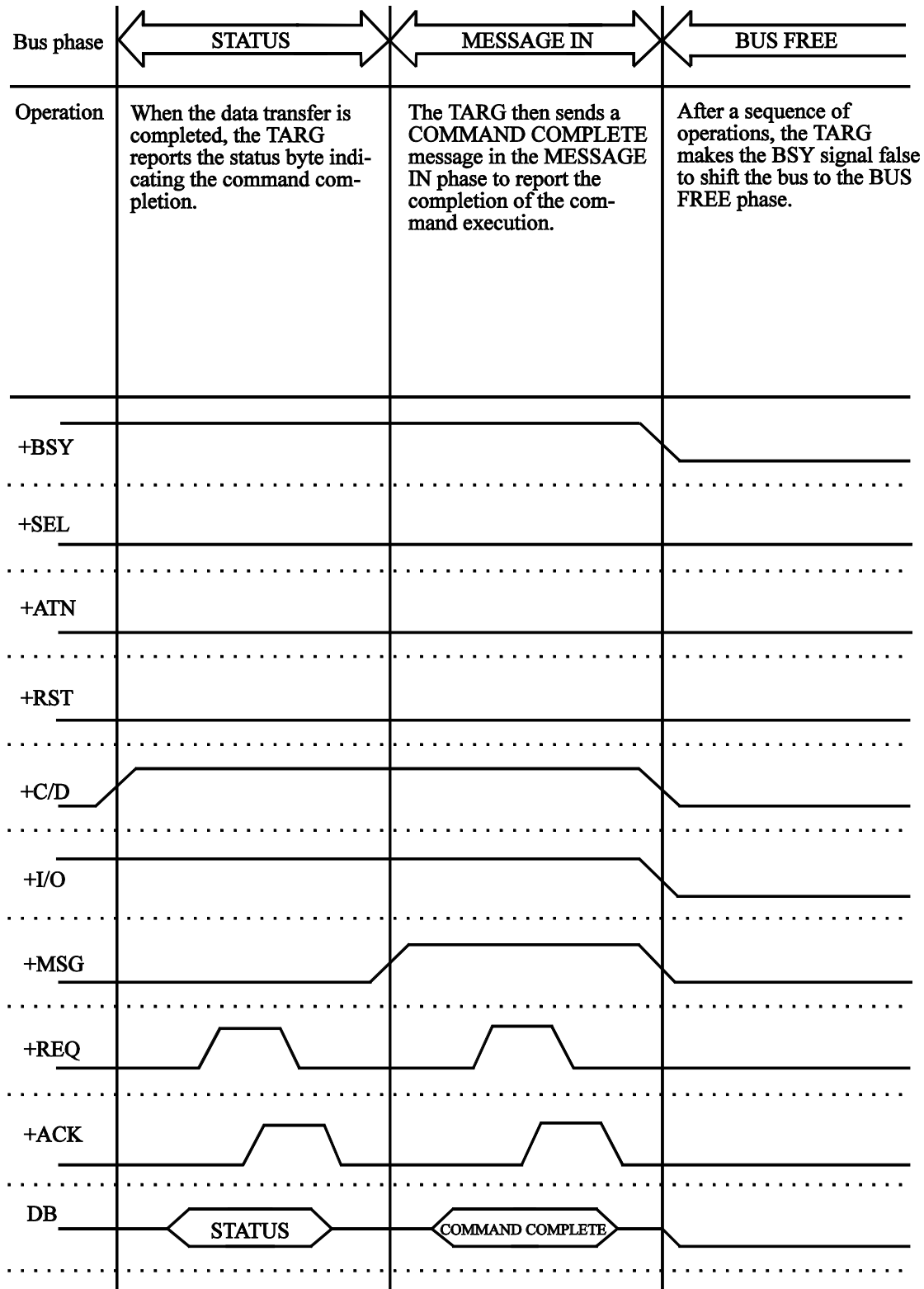

Figure 7.22 Example of bus phase transition on execution of a single command (5 of 5)

# Glossary

## **Axial acceleration**

Acceleration in the recording layer along the line perpendicular to the disk reference surface at a specified rotation speed. Axial acceleration is detected by optical means.

## **Axial displacement**

A displacement at a point in the recording layer in a direction perpendicular to the disk reference surface from its standard position. The standard position in the recording layer is detected optically using the thickness and refraction rate of the protective layer, based on the disk reference surface.

## **Case**

A cover of an optical disk. The case protects the disk from being damaged during handling and also allows the operator to replace disks easily. The case also provides for a label, write protection tab, automatic handling support, and media identification hole.

## **CDB (Command Descriptor Block)**

A series of data describing input-output commands. The CDB is sent from the initiator to the target.

## **Clamp area**

A disk ring area on which the clamp mechanism applies a clamp force.

## **Command**

An input-output instruction to the target. Described as CDB.

## **Control track**

A track used to store media parameters and format information required to record and read data to or from an optical disk.

## **Defect management**

In real time processing mode, defect management refers to an automatic program used to change the power, focus, tracking of reading and recording if an error is detected and used to decide whether numerous error sectors should be discarded. In batch mode, defect management refers to a guideline used to re-record or save data in a disk.

**Disk reference surface**

An ideal flat ring surface of an ideal spindle that comes into contact with the clamp area on a disk. The disk reference surface is perpendicular to the rotation axis.

**Error correction code**

An error correction code designed to correct specific errors in data.

**Error detection and correction**

A series of methods used to add a redundant code to data in the existing format and then record data. In read mode, the decoder removes a redundant code and detects and corrects errors using the redundant information.

**Interleaving section**

A process that physically arranges data units so that data resists burst errors.

**LUN (Logical Unit Number)**

A device address used to identify a logical unit.

**Recording layer**

A disk layer in which data should be recorded during manufacturing or recording.

**Recording power**

An incidence power specified on the incidence surface and used to form marks.

**Sense code**

A single-byte code set in sense data. This information is used to identify the type of error detected.

**Sense data**

Information generated by the target to report detailed error information if a command end status contains any error information.

**Sense key**

A 4-bit code set in sense data. This information is used to classify the type of error detected.

**Spindle**

A disk drive component that comes into contact with a disk and a hub.

**Status**

Single-byte information reported from the target to the initiator at the end of execution of each command. The status indicates the end status of a command.

This page is intentionally left blank.

# Acronyms and Abbreviations

<b>A</b>		<b>E</b>	
AC	Alternating current	EBC	Enable blank check
ACK	Acknowledge	EBP	Erase by-pass
ALPC	Automatic laser power control	ECC	Error correcting code
AM	Address mark	EN	European Norm
ANSI	American National Standards Institute	EVPD	Enable vital product data
ARRE	Automatic read reallocation enabled	<b>F</b>	
ASC	Additional sense code	FG	Frame ground
ASCII	American Standard Code for Information Interchange	FIFO	First in first out
ASCQ	Additional sense code qualifier	FmtData	Format data
ATN	Attention	FOV	Format options valid
AWG	American Wire Gauge	FRU	Field replaceable unit
AWRE	Automatic write reallocation enabled	<b>G</b>	
<b>B</b>		GND	Ground
BCV	Buffer control valid	<b>I</b>	
BPV	Bit pointer valid	I/O	Input/output
BSY	Busy	IC	Integrated circuit
BytChk	Byte check	ID	Identifier
<b>C</b>		IDD	Intelligent disk drive
C/D	Control/data	IEC	International Electrotechnical Commission
CDB	Command descriptor block	Immed	Immediate
CDRH	Center for Devices and Radiological Health	IP	Initialize pattern
CRC	Cyclic redundancy code	ISO	International Standardization Organization
CSA	Canadian Standards Association	<b>L</b>	
<b>D</b>		LD	Laser diode
DB	Data bus	LED	Light emitting diode
DBD	Disable block descriptor	LoEj	Load eject
DBP	Data bus parity	LSB	Least significant byte
DC	Direct current	LUN	Logical unit number
DCRT	Disable certification	<b>M</b>	
DDS	Disk definition sector	MPU	Microprocessor unit
DMA	Defect management area	MSB	Most significant byte
DPO	Disable page out	MSG	Message
DPRY	Disable primary	MTBF	Mean time between failures
DSP	Digital signal processor	MTTR	Mean time to repair

<b>N</b>		<b>T</b>	
N.C.	No connection	TTL	Transister-transister-logic
		Typ	Typical
<b>O</b>		<b>U</b>	
ODD	Optical disk drive	UB	User band
ODF	Offset detection flag	UL	Underwriters Laboratories Incorporated
OEM	Original equipment manufacturer		
<b>P</b>		<b>V</b>	
PA	Postamble	VCM	Voice coil motor
P/N	Part number	VDE	Verband Deutscher Elektrotechniker
PC	Page control	VFO	Variable frequency oscillator
PCA	Printed circuit assembly	VLD	Valid
PCF	Page control field	VPD	Vital product data
PCR	Parameter code reset	VU	Vendor unique
PDL	Primary defect list		
PEP	Phase encoded part		
PF	Page format		
PLL	Phase-locked loop		
PMI	Partial medium indicator		
PPC	Parameter pointer control		
PWM	Pulse width modulation		
<b>R</b>			
RAM	Random-access memory		
RelAdr	Relative addressing		
REQ	Request		
RH	Relative humidity		
ROM	Read only memory		
rpm	revolutions per minute		
RST	Reset		
RSV	Reserved		
<b>S</b>			
S/N	Serial number		
SB	Spare band		
SCT	Sector		
SDL	Secondary defect list		
SDTR	Synchronous data transfer request		
SEL	Select		
SFP	Standard formatted part		
SG	Signal groun		
SKSV	Sense key specific valid		
SM	Sector mark		
SNSKEY	Sense key		
SP	Save page		
SP	Save parameter		
STPF	Stop format		
SYNC	Synchronization mark		



# Index

128 MB media 2-10  
1.3 GB media 2-11  
230 MB media 2-10  
25.4 mm height 1-1  
540 MB/640 MB media 2-10

## A

ACK 7-5  
actuator section 1-8  
adaptability 1-3  
air cleanliness 3-4  
algorithm for alternate processing 2-11  
allowable input voltage and current 3-14  
appearance 1-6, 2-8, 5-6  
appearance of  
    optical disk cartridge 5-7  
    optical disk drive 5-1  
ARBITRATION phase 7-20, 7-21  
asynchronous transfer 7-28  
ATN 7-5  
ATTENTION 7-5  
ATTENTION condition 7-40  
Australian EMC standard 1-4  
automatic allocation of alternate data block  
    1-3  
automatic spindle stop function 1-2

## B

bit error rate after ECC processing 2-5  
block diagram of control circuit section 1-9  
BSY 7-4  
bus condition 7-40  
BUS FREE phase 7-18  
bus phase 7-18  
    sequence 7-46, 7-47  
bus sequence 7-45  
BUSY 7-4

## C

cable connection 4-13  
    mode 3-19  
    requirement 3-19  
cable side 7-7

Canada safety standard 1-4  
cartridge case 2-9  
catalog 2-1  
C/D 7-5  
CDRH 1-4  
center of gravity 3-11  
change of revision number in field 6-4  
checking panel function 3-13  
checks before mounting the drive 4-12  
checks if errors occur at initial self-diagnosis  
    4-14  
cleaning 5-1  
    kit 5-10  
    optical disk cartridge 5-10  
    tool for optical disk cartridge 5-10  
cleaning of  
    disk surface 5-14  
    optical disk cartridge 5-11  
    optical disk drive 5-5  
COMMAND phase 7-33  
compatibility with international standard  
    (media interchangeability) 1-2  
configuration 1-7  
    optical disk drive 1-6, 1-7  
confirming initial operation 4-14  
conformation to SCSI-2 1-4  
connecting  
    one optical disk drive 4-4  
    more than one optical disk drive 4-4, 4-5  
connection  
    mode 4-4  
    of interface cable 7-10  
    requirement 3-17  
connection to  
    middle point of cable 7-10  
    end of cable 7-10  
connector 3-17  
connector and terminal location 3-17  
continuous block processing 1-4  
control circuit section 1-8  
CONTROL/DATA 7-5  
CSA C22.2 No. 950 1-4  
current waveform  
    (+5 VDC) 3-14  
    (reference) 3-14

## D

DATA BUS and SCSI ID 7-4  
DATA IN phase 7-33  
DATA OUT phase 7-33  
DATA phase 7-33  
data transfer rate  
    in asynchronous mode 7-33  
    in synchronous mode 7-34, 7-35  
defective block slipping 1-5  
defect management 2-11  
    schematic diagram 2-11  
device type mode 3-23  
    setting 3-23  
diagnostic 6-1  
    command 6-2  
    function 1-3, 6-1  
disk specification 2-10  
dismounting drive 4-17  
drive circuit section 1-9  
driver and receiver 7-11  
dust resistance 1-2

## E

EN60825-1 1-4  
EN60950 1-4  
electrical requirement 7-11  
enhanced error recovery 1-3  
environmental 2-4  
    requirement 3-1  
error rate 2-5  
European  
    safety standard 1-4  
    laser standard 1-4  
example of  
    alternate processing 2-12  
    bus phase transition on execution of a single  
        command 7-48 to 7-52  
    SCSI configuration 7-2  
external  
    light source 3-13  
    magnetic field 3-13  
external operator panel 3-20  
    circuit example 3-21  
    interface 3-22  
    interface connector 3-22  
    settings 3-23

## F

feature 1-1  
five-year service life 1-3  
function 1-1

## G

general  
    description 1-1  
    note 4-1  
generation and release of ATTENTION  
    condition (INIT) 7-40

## H

half-height standard 90mm (3.5-inch) size  
    (25.4 mm height) 1-1  
head cleaner 5-5  
high-capacity data buffer 1-4  
high-speed  
    data transfer 1-1  
    mean seek time 1-2

## I

if processing terminates abnormally 4-17  
INIT 7-40  
INFORMATION TRANSFER phase 7-26  
    identification 7-5  
indication of revision number at shipment  
    6-4  
initial self-diagnostic 6-1  
INPUT/OUTPUT 7-5  
inserting optical disk cartridge 5-2, 5-3  
inside optical disk cartridge 3-1  
installation 4-1, 4-2  
    direction 3-10  
    requirement 3-1  
interface 1-4  
    connector 7-6  
    signal definition 7-3  
interface cable 7-9  
    requirement 7-9  
interlock type 7-28  
I/O 7-5

## L

leak magnetic field 3-13  
loading and ejecting optical disk cartridge  
    1-7

logical specification type setting 3-24  
 lower power consumption 1-2  
 low noise 1-3

**M**

maintainability 1-3  
 maintenance 6-1  
   information 6-2  
   requirement 6-2  
 MESSAGE 7-5  
   phase 7-36  
 MESSAGE IN phase 7-36  
 MESSAGE OUT phase 7-36  
 MCM3130SS current waveform (+5 VDC)  
   3-14  
 mean time between failure 1-3, 2-6  
 mechanical section 1-7  
 media interchangeability 1-2  
 mounting 4-12  
   frame structure 3-12  
   procedure 4-13  
   requirement 3-4  
 MPU 6-1  
 MSG 7-5  
 MTBF 1-3, 2-6  
 multi-host 4-5

**N**

no overhaul 1-3  
 noise filter 3-16  
 notes on drive handling 4-1

**O**

ODD side 7-6  
 opening shutter 5-11  
 operability 1-3  
 operation 5-1  
   confirmation and preparation for use after  
     installation 4-14  
   of optical disk cartridge 5-6  
   of optical disk drive 5-1  
 optical disk cartridge 2-8  
 optical disk drive  
   (without panel) 1-6  
   (with panel) 1-6  
   front view (with panel) 5-1  
 order number 2-1  
 outer dimension 3-4 to 3-9

**P**

packing 4-2  
 packing list for cleaning kit 5-10  
 packing style  
   individual 4-3  
   gathered 4-3  
 panel 1-8  
 parameters used for synchronous data  
   transfer 7-35  
 performance 1-1  
 phase control 7-27  
 physical requirement 7-6  
 placing setting case cover 5-12  
 positioning error rate 2-5  
 positions of setting terminal and switch 4-5  
 power on/off sequence 3-14, 3-15  
 power requirement 2-4  
 power supply  
   requirement 3-14  
   cable 3-20  
   connector 3-16  
   for terminating resistor 7-12  
   to SCSI terminating resistor 3-16  
 power switch off setting 3-17  
 precaution 5-2, 5-9  
   on mounting 3-12  
   on use and storage of cleaning kit 5-11  
 pre-idle mode 4-40  
 preventive maintenance 6-2  
 procedure 4-15

**R**

radio wave standard 1-4  
 RAM 6-1  
 random/sequential read test 6-2  
 read-ahead cache feature 1-4  
 recommended components for connection  
   3-20  
 recommended optical disk cartridge 2-7  
 reliability 1-3, 2-6  
 removing optical disk cartridge 5-4  
 representative model name 2-1  
 REQ 7-5  
 REQUEST 7-5  
 requirement for terminating resistor power  
   supply 7-12  
 RESELECTION phase 7-24

- RESET 7-5
    - condition 7-42, 7-44
  - response against ATTENTION condition (TARG) 7-41
  - response sequence 7-22, 7-25
  - revision
    - label 6-3
    - number 6-3
    - number indication 6-4
  - RST 7-5
- S**
- safety standard 1-4
  - SCSI BUS 7-1
    - connection mode 4-4, 4-5
    - timing specification 7-17
  - SCSI cable 3-20
  - SCSI connection check 4-15, 4-16
  - SCSI connector 3-18
  - SCSI controller circuit section 1-9
  - SCSI data bus parity checking 4-8 (SW1) 4-8
  - SCSI ID 4-8
    - setting (SW1) 4-8
  - SCSI interface 7-11
    - connector 7-6, 7-7
    - connector pin assignment 7-8
  - SCSI terminating resistor mode 4-11 (CNH1) 4-11
  - SCSI terminating resistor power supply (CNH1) 4-10
  - SCSI termination circuit 7-12
  - SCSI type 0 3-24
  - SEL 7-5
  - SELECT 7-5
  - SELECTION phase 7-22, 7-23
  - separate optical section 1-8
  - service
    - area 3-13
    - life 2-6, 6-2
    - system and repair 6-2
  - setting 4-5
    - checklist 4-12
    - of supplying power to SCSI terminating resistor 4-10
    - optical disk cartridge into setting case 5-12
    - switches (SW1) 4-7
    - value of SCSI time monitoring 7-39
  - single-ended type 7-8
  - single
    - host 4-4
    - driving method 7-13
    - source 7-14
    - status value 7-13
    - requirements concerning transition between bus phases 7-37
  - specification 2-1
  - specification of
    - disk 2-10
    - drive 2-2
    - optical disk cartridge 2-7
    - optical disk drive 2-1
  - spindle motor 1-7
  - start sequence 7-24
    - without ARBITRATION phase 7-22
    - with ARBITRATION phase 7-22
  - STATUS phase 7-36
  - storage 4-3
  - storing cartridge 5-9
  - surface temperature measurement point 3-1
  - synchronous mode 7-29
  - system ground (handling of SG and FG) 3-13
  - system configuration 7-1
  - switching direction of transfer over data bus 7-38
- T**
- Taiwanese EMC standard 1-4
  - TARG 7-40
  - temperature measurement point 3-1
    - (reference) 3-3
  - temperature requirement 3-2
    - at measurement point 3-2
  - temperature rise 3-3
  - terminal 3-17
  - termination circuit 7-12
  - test program 6-2
  - time monitoring
    - of ACK response wait 7-32
    - in INFORMATION TRANSFER phase 7-38
    - in RESELECTION phase 7-38
    - feature 7-38
  - timing
    - rule 7-15
    - specification 7-15 to 7-17
  - timeout procedure 7-24, 7-26
  - transfer
    - from INIT to TARG 7-28, 7-31
    - from TARG to INIT 7-28, 7-31
    - in asynchronous mode 7-29
    - in synchronous mode 7-32

transportation 4-3  
transporting cartridge 5-9

**U**

UL1950 1-4  
unpackaging 4-1  
    drive 3-18  
using cartridge 5-9  
U.S.  
    safety standard 1-4  
    laser standard 1-4

**V**

verify mode 3-23

**W**

while drive is  
    powered off 5-3, 5-4  
    powered on 5-2, 5-4  
wide-ranging operating environment 1-3  
write cache  
    feature 1-5  
    mode 4-9  
    mode setting 4-9  
write protect tab 2-9, 5-8  
write/read test 6-2  
write verify mode setting 3-23

This page is intentionally left blank

## READER'S COMMENT FORM

Your comments or suggestions on this document are cordially solicited. For any comments and suggestions you may have, please complete and submit this form to your FUJITSU representative. The comments and suggestions will be used in planning future editions. Thank you for your cooperation.

Date issued: \_\_\_\_\_ Manual name: MCM3064SS, MCM3130SS,  
MCP3064SS, MCP3130SS OPTICAL  
DISK DRIVES PRODUCT MANUAL

Name: \_\_\_\_\_ Manual code: C156-E228-02EN  
Company or organization: \_\_\_\_\_

Address: \_\_\_\_\_

Comments:

Page	Line	Comments

Reply requested:  Yes  No

Please evaluate overall quality of this manual by marking (√) in the appropriate boxes.

	Good Fair Poor		Good Fair Poor		Good Fair Poor
Organization:	<input type="checkbox"/> <input type="checkbox"/> <input type="checkbox"/>	Use of examples:	<input type="checkbox"/> <input type="checkbox"/> <input type="checkbox"/>	Legibility:	<input type="checkbox"/> <input type="checkbox"/> <input type="checkbox"/>
Accuracy:	<input type="checkbox"/> <input type="checkbox"/> <input type="checkbox"/>	Index coverage:	<input type="checkbox"/> <input type="checkbox"/> <input type="checkbox"/>	Handiness/Binding:	<input type="checkbox"/> <input type="checkbox"/> <input type="checkbox"/>
Clarity:	<input type="checkbox"/> <input type="checkbox"/> <input type="checkbox"/>	Cross referencing:	<input type="checkbox"/> <input type="checkbox"/> <input type="checkbox"/>	_____ (Others):	<input type="checkbox"/> <input type="checkbox"/> <input type="checkbox"/>
Figures & tables:	<input type="checkbox"/> <input type="checkbox"/> <input type="checkbox"/>	General appearance:	<input type="checkbox"/> <input type="checkbox"/> <input type="checkbox"/>		
Technical level:	Too high <input type="checkbox"/>	Appropriate <input type="checkbox"/>	Too low <input type="checkbox"/>		
Overall rating of this publication:	Good <input type="checkbox"/>	Fair <input type="checkbox"/>	Poor <input type="checkbox"/>		

### FOR FUJITSU USE

Overseas office: \_\_\_\_\_ Person in charge: \_\_\_\_\_

Note) Local representative should pass this form to the section in charge of distribution in FUJITSU.

Reply

By \_\_\_\_\_

This page is intentionally left blank





**FUJITSU**